



IDEAL INDUSTRIES, INC.

Partner in Poland: Vemco Sp. z o.o., www.vemco.pl

TECHNICAL MANUAL IDEAL OTDR



Copyright © 2008 IDEAL All rights reserved. No part of this publication may be reproduced, stored in a retrieval system or transmitted in any form, be it electronically, mechanically, or by any other means such as photocopying, recording or otherwise, without the prior written permission of IDEAL (IDEAL).

Information provided by IDEAL is believed to be accurate and reliable. However, no responsibility is assumed by IDEAL for its use nor for any infringements of patents or other rights of third parties that may result from its use. No license is granted by implication or otherwise under any patent rights of IDEAL.

IDEAL's Commerce And Government Entities (CAGE) code under the North Atlantic Treaty Organization (NATO) is 0L8C3.

The information contained in this publication is subject to change without notice.

Trademarks

IDEAL's trademarks have been identified as such. However, the presence or absence of such identification does not affect the legal status of any trademark.

Units of Measurement

Units of measurement in this publication conform to SI standards and practices.

Version number: 4.0.1

Contents

Certification Information	vi
1 Introducing the IDEAL OTDR	1
Main Features	1
Power Sources	5
Typical Applications	5
OTDR Basic Principles	6
Conventions	8
2 Safety Information	9
Laser Safety Information (Units without VFL)	9
Laser Safety Information (Units with VFL)	10
Electrical Safety Information	10
3 Getting Started with Your OTDR	11
Turning the Unit On and Off	11
Using Menus and Keypad	13
4 Customizing Your OTDR	15
Selecting the Distance Units	15
Selecting the Language of Operation	16
Setting the Date and Time	17
Adjusting the Brightness	18
Selecting a Printer	19
Configuring the Power Management Settings	20
5 Setting Up Your OTDR	21
Installing the Universal Interface (UI)	21
Cleaning and Connecting Optical Fibers	22
Setting General OTDR Parameters	23
Setting the Acquisition Parameters	25
Setting Analysis Parameters	28
Setting Pass/Fail Thresholds	30
Setting Macrobend Parameters	32
Setting Storage Parameters	34

Contents

6 Testing Fibers	37
Testing in Auto Mode	38
Testing in Fault Finder Mode	41
Testing in Manual (Advanced) Mode	43
Monitoring Fiber in Real Time Mode	46
Launch Conditions for Multimode Measurements	49
7 Managing Test Results	51
Summary Pane	51
Events Pane	52
Trace Pane	53
Trace Info. Pane	54
Using Markers	56
Using Zoom Controls	57
Printing Test Results	59
Opening Trace Files	60
Saving Files	61
Checking Available Memory	63
Creating Folders	63
Copying, Renaming, or Deleting Files and Folders	64
Transferring Results to a Computer	66
8 Using Your OTDR as a Light Source	71
Activating/Deactivating a Light Source	72
Modulating the Source Signal	73
9 Maintenance	75
Cleaning UI Connectors	76
Recharging Main Batteries	78
Replacing Batteries	79
Recalibrating the Unit	80
Upgrading the IDEAL OTDR Software	81
Recycling and Disposal (Applies to European Union Only)	83
10 Troubleshooting	85
Solving Common Problems	85
Obtaining Online Help	88
Customer Support and Technical Assistance	89
Transportation	91

11 Warranty	93
General Information	93
Liability	93
Exclusions	94
Service and Repairs	95
IDEAL Service Centers Worldwide	96
A Description of Event Types	97
Span Start	97
Span End	97
Continuous Fiber	98
End of Analysis	99
Non-Reflective Event	100
Positive Event	101
Launch Level	102
Fiber Section	103
Reflective Event (Possible Echo)	104
Echo	105
Merged Reflective Event	106
Reflective Event	108
Index	109

Certification Information

F.C.C. Information

Electronic test equipment is exempt from Part 15 compliance (FCC) in the United States. However, compliance verification tests are systematically performed on most IDEAL equipment.

CE Information

Electronic test equipment is subject to the EMC Directive in the European Union. The EN61326 standard prescribes both emission and immunity requirements for laboratory, measurement, and control equipment. This unit has undergone extensive testing according to the European Union Directive and Standards.



DECLARATION OF CONFORMANCE

**Ideal Industries Limited
Unit 3, Europa Court
Europa Boulevard
Westbrook
Warrington
Cheshire
WA5 7TN
United Kingdom**

Declare that the following product(s):

IDEAL 33-960 Series handheld OTDR with all accessories

to which this declaration relates are in conformity with the following standard(s) or other normative document(s):

- | | |
|-------------------------|--|
| EN 55022:1998/A2:2003 | Limits and Methods of Measurement of Radio Disturbance Characteristics of Information Technology Equipment |
| EN 60825-1:1994/A2:2001 | Safety of laser products – Part 1: Equipment classifications, requirements, and user's guide |
| EN 61326:1997/A3:2003 | Electrical Equipment for Measurement, Control and Laboratory Use – EMC Requirements |

following the provisions of the following European Community Directives:

89/336/EEC Electromagnetic Compatibility and 72/23/EEC Low Voltage Safety.

Issued on 1st of July, 2008

For and on behalf of Ideal Industries at the above address

A handwritten signature in black ink that reads "A. Kumeta".

Tony Kumeta,
European General Manager

Ideal Industries Limited
Unit 3, Europa Court
Europa Boulevard
Westbrook
Warrington
Cheshire
WA5 7TN
United Kingdom
www.europe.idealindustries.de

1 Introducing the *IDEAL OTDR*

The IDEAL OTDR is a compact handheld OTDR optimized for access/FTTx network testing. The unit can be equipped with optional power meter, visual fault locator (VFL), and fiber inspection probe.

Main Features

- Test can be started by pressing a single key
- Possible to test with acquisition duration as short as 5 seconds
- One or two OTDR ports (singlemode, multimode, or filtered wavelength)
- Screen optimized for outdoor use
- USB ports (host and client)

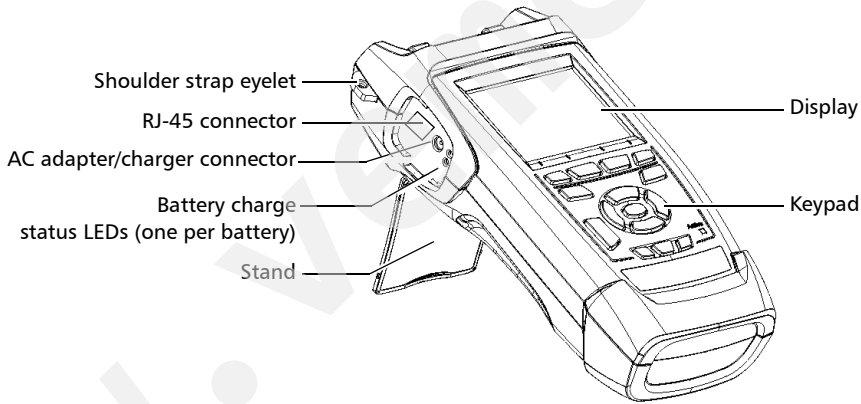

Introducing the IDEAL OTDR

Main Features

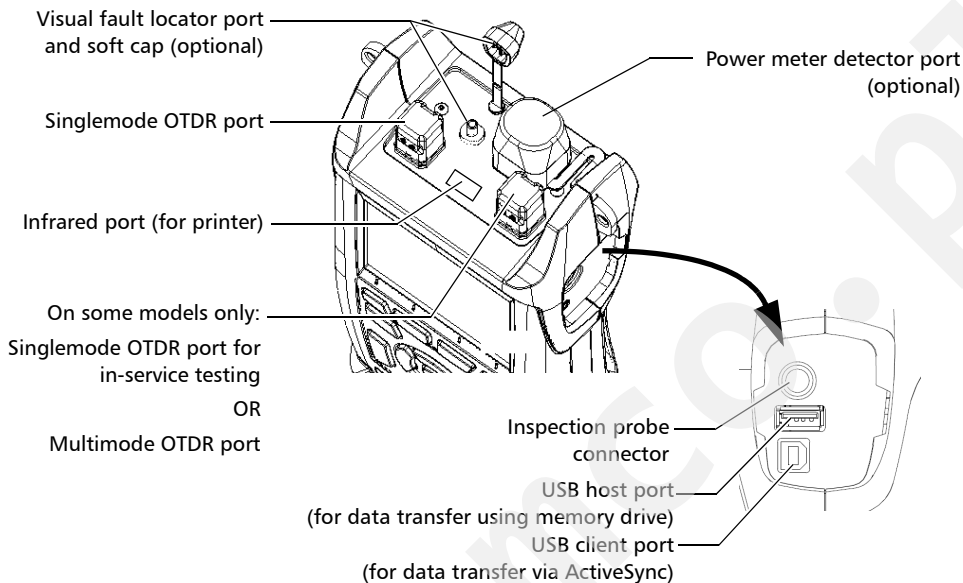

Note: Ports and connectors on your unit may differ from the illustration.

Other test utilities:

- Visual fault locator to inspect or identify fibers (optional)
- Video fiber inspection probe (optional)
- Power meter (optional)

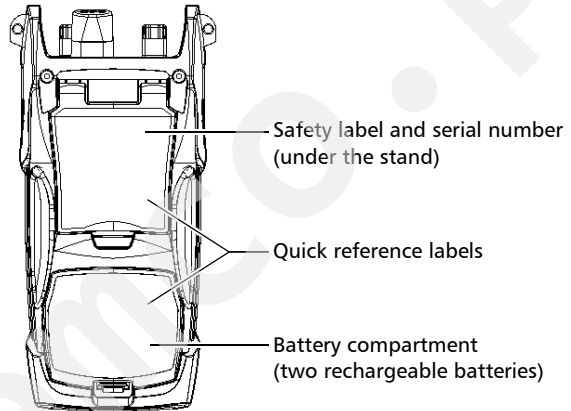

Introducing the IDEAL OTDR

Main Features

Other useful characteristics:

- Customizable test thresholds with visual pass/fail analysis
- Memory for 500 OTDR traces and possible data transfer to a computer
- Energy-saving features: automatic backlight or unit shutdown
- Multilingual graphical user interface
- Comprehensive online help available from each function and Quick Reference labels affixed to back of unit
- Data post-processing: You can install the OTDR Viewer software (provided on the installation CD) on a computer to view and analyze OTDR traces. You can access more features such as:
 - customized printout
 - batch printing
 - conversion of traces to many formats such as Telcordia or ASCII.

Power Sources

The unit operates with the following power sources:

- AC adapter/charger (connected to standard power outlet—indoor use only). Compatible car outlet adapter available upon request.
- Two lithium-ion rechargeable batteries (automatically take over if you disconnect the AC adapter/charger). Battery recharge is automatic when the AC adapter/charger is connected.

Typical Applications

You can use the OTDR for several applications, such as:

- Short-link testing
- Service activation
- Fault finder
- Troubleshooting (dark and live fibers)

OTDR Basic Principles

An OTDR sends short pulses of light into a fiber. Light scattering occurs in the fiber due to discontinuities such as connectors, splices, bends, and faults. An OTDR then detects and analyzes the backscattered signals. The signal strength is measured for specific intervals of time and is used to characterize events.

The OTDR calculates distances as follows:

$$\text{Distance} = \frac{c}{n} \times \frac{t}{2}$$

where

- c = speed of light in a vacuum (2.998×10^8 m/s)
- t = time delay from the launch of the pulse to the reception of the pulse
- n = index of refraction of the fiber under test (as specified by the manufacturer)

An OTDR uses the effects of Rayleigh scattering and Fresnel reflection to measure the fiber condition, but the Fresnel reflection is tens of thousands of times greater in power level than the backscatter.

- Rayleigh scattering occurs when a pulse travels down the fiber and small variations in the material, such as variations and discontinuities in the index of refraction, cause light to be scattered in all directions. However, the phenomenon of small amounts of light being reflected directly back toward the transmitter is called backscattering.
- Fresnel reflections occur when the light traveling down the fiber encounters abrupt changes in material density that may occur at connections or breaks where an air gap exists. A very large quantity of light is reflected, as compared with the Rayleigh scattering. The strength of the reflection depends on the degree of change in the index of refraction.

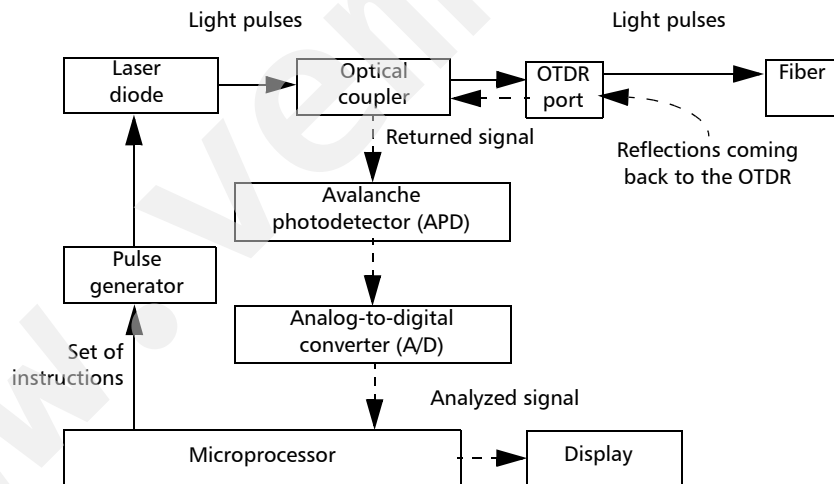

When the full trace is displayed, each point represents an average of many sampling points. You will have to zoom to see each point (see *Using Zoom Controls* on page 57).

Conventions

Before using the product described in this manual, you should understand the following conventions:



WARNING

Indicates a potentially hazardous situation which, if not avoided, could result in *death or serious injury*. Do not proceed unless you understand and meet the required conditions.



CAUTION

Indicates a potentially hazardous situation which, if not avoided, may result in *minor or moderate injury*. Do not proceed unless you understand and meet the required conditions.



CAUTION

Indicates a potentially hazardous situation which, if not avoided, may result in *component damage*. Do not proceed unless you understand and meet the required conditions.



IMPORTANT

Refers to information about this product you should not overlook.

2 Safety Information



WARNING

Do not install or terminate fibers while a light source is active. Never look directly into a live fiber and ensure that your eyes are protected at all times.



WARNING

Use of controls, adjustments and procedures for operation and maintenance other than those specified herein may result in hazardous radiation exposure or impair the protection provided by this unit.

Laser Safety Information (Units without VFL)

Your instrument is a Class 1M laser product in compliance with standards IEC 60825-1 Amendment 2: 2001 and 21 CFR 1040.10. Invisible laser radiation may be encountered at the output port.

The product is safe under reasonably foreseeable conditions of operation but it may be hazardous if you use optics within a diverging or collimated beam. *Do not view directly with optical instruments.*



Affixed to back
(under the stand)

Safety Information

Laser Safety Information (Units with VFL)

Laser Safety Information (Units with VFL)

Your instrument is a Class 3R laser product in compliance with standards IEC 60825-1 Amendment 2: 2001 and 21 CFR 1040.10. It is potentially harmful in direct intrabeam viewing.

The following label(s) indicate that the product contains a Class 3R source:



Affixed to back
(under the stand)

VFL
Laser
Aperture

Indicated on
connector panel

Electrical Safety Information

The AC adapter/charger provided with this unit (14.4 W/9 V) is specifically designed to work with your IDEAL OTDR.



WARNING

Use the AC adapter/charger indoors only.

Any other AC adapter/charger or power source
(for example, car outlet) must output at least 12 W.



3 Getting Started with Your OTDR

Turning the Unit On and Off

When you turn the unit on, you may use it immediately under normal conditions.

When the unit is turned off, it keeps the following parameters in its internal memory:

- Test parameters
- User-defined thresholds
- Regional, LCD, and energy-saving settings
- Saved test results



IMPORTANT

If you remove batteries (and the AC adapter/charger is disconnected), the unit will turn off *without saving the above elements*.

Getting Started with Your OTDR

Turning the Unit On and Off

There are two ways to turn off the IDEAL OTDR

- *Suspend*: the next time you turn your unit on, you will quickly return to your work environment.
- *Shutdown*: completely cuts power to the unit; the unit will perform a complete restart routine the next time you use it. You should perform a shutdown if you do not intend to use your unit for a week or more.

To turn the unit on:

Press Pwr. The unit initializes for a few seconds and displays the **OTDR Parameters** pane.

To enter the suspend mode:

Hold down the Pwr key for about two seconds. Release the key as soon as you hear a beep.

To perform a shutdown:

Hold down the Pwr key for about five seconds. You will hear a first beep; release the key after you hear a second beep.

Using Menus and Keypad

You can access optical tools from the keypad or menu. Menu options may differ depending on your unit configuration.

Status Bar

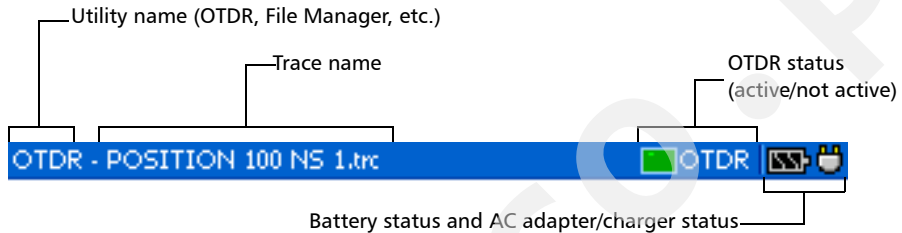

Keypad

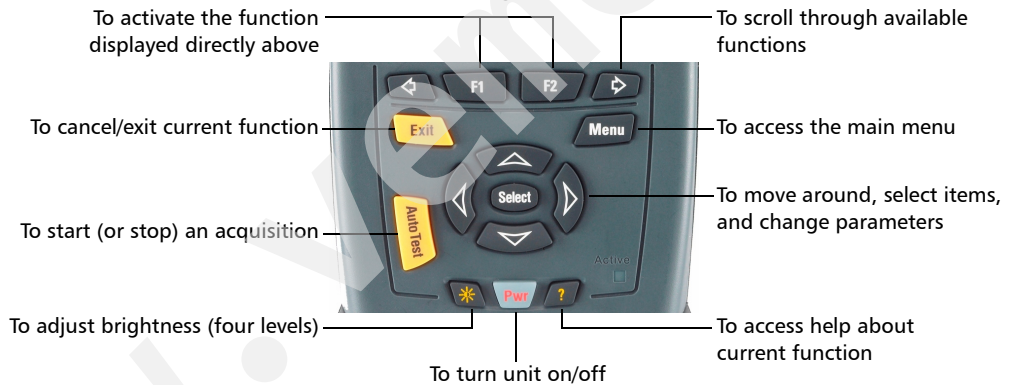

To access main features:

1. Press the Menu key.
2. Use the arrows to select a feature and press Select.

Getting Started with Your OTDR

Using Menus and Keypad

To activate F1/F2 functions:

1. Use the left/right function arrows (on each side of the F1/F2 keys) to display the desired function or parameter.
2. Press the F1 or F2 key located just below.

To access and modify on-screen parameters:

1. Use the arrows to select an on-screen item (list, check box, etc.).
2. Press Select to activate or open it.

To enter text or numbers with an on-screen keyboard:

- Use the left/right function arrows (on each side of the F1/F2 keys) to move the cursor in the text.
- Use the up/down and left/right arrows to select a character, and then press Select to add it.
- Press **OK** (F1 key) to accept the element, and then hide the keyboard.

4 Customizing Your OTDR

Selecting the Distance Units

There are three distance units available: meters, miles, and kilofeet.

Note: *The attenuation values are always expressed in dBs per kilometer.*

To select distance units:

1. Press Menu, select **Setup > Unit**, and then press Select.
2. Use the left/right function arrows until you see **Regional Settings**, and then press **F2** to display the pane.
3. Press Select to open the **Distance unit** list.
4. With the current distance unit highlighted, use the up/down arrows to select the desired unit, and then press Select to activate it.

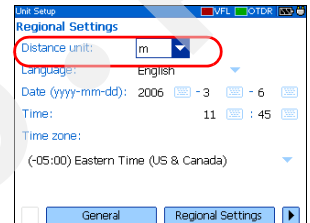

Selecting the Language of Operation

You may display the user interface in one of the available languages (default is English). If other languages become available in the future, you could access them by replacing the unit software (see *Upgrading the IDEAL OTDR Software* on page 94). Values are kept in memory when you turn the unit off.

To select a new interface language:

1. Press Menu, select **Setup > Unit**, and then press Select.
2. Use the left/right function arrows until you see **Regional Settings**, and then display the pane (F1/F2 key).
3. Use the up/down arrows to select the **Language** list, and then press Select to open it.
4. With the current language highlighted, use the up/down arrows to select the desired language, and then press Select to activate it.

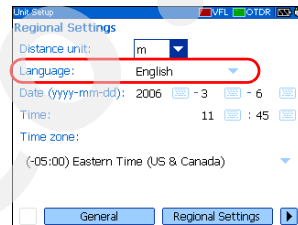

Once you have modified the language, you will be prompted to restart your unit.

Setting the Date and Time

When saving results, the unit also saves the corresponding date and time.

You must enter the date according to the year-month-day format and the time according to the 24-hour format.

You can also modify the time zone.

To set the date and time:

1. Press Menu, select **Setup > Unit**, and then press Select.
2. Use the left/right function arrows until you see **Regional Settings**, and then display the pane (F1/F2 key).
3. Use the arrows to select any of the date or time settings, and then press Select to display the [on-screen keyboard](#) (for details about using keyboards, see *Using Menus and Keypad* on page 13).
4. Enter the new value and press **OK** (F1/F2 key).

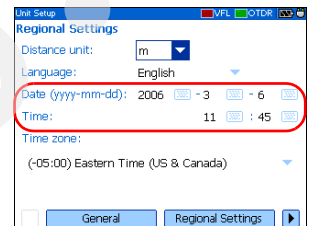

To modify the time zone:

1. Press Menu, select **Setup > Unit**, and then press Select.
2. Use the left/right function arrows until you see **Regional Settings**, and then display the pane (F1/F2 key).
3. Use the arrows to select the **Time zone** list, and then press Select to open it.
4. With the current time zone highlighted, use the up/down arrows to select the desired time zone, and then press Select to activate it.

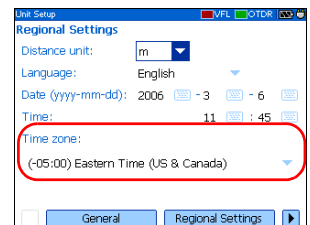

Adjusting the Brightness

To fit your work environment, you may adjust the LCD brightness. Values are kept in memory when you turn the unit off.

To adjust the display brightness:

Press the * key repeatedly to switch between brightness levels (0-3-6-9).

OR

1. Press Menu, select **Setup > Unit**, and then press Select.
2. If necessary, use the left/right function arrows until you see **General**, and then display the pane (F1/F2 key).

By default, the **Brightness** slider is selected.

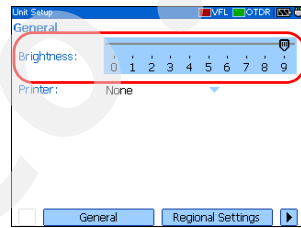

3. Use the left/right arrows to adjust the brightness level.

Selecting a Printer

To print reports, you must configure the printer first. Your unit supports the *Printek 2"* printer only and communicates with it via the infrared port located on the top panel.

If you want to print on a network printer or if you want to print other type of reports, you must transfer the desired files on a computer on which OTDR Viewer is installed.

To select a printer:

1. Press Menu, select **Setup > Unit**, and then press Select.
2. If necessary, use the left/right function arrows until you see **General**, and then display the pane (F1/F2 key).
3. Use the up/down arrows to select the **Printer** list, and then press Select to open it.
4. With the current printer highlighted, use the up/down arrows to select the desired printer, and then press Select to activate it.

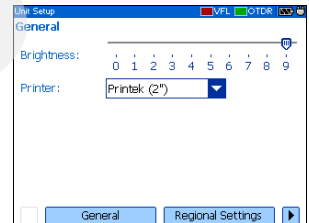

Configuring the Power Management Settings

When you do not use the unit for a while, the display may be dimmed to save power.

You can set idle durations for AC adapter/charger and battery operation. The unit goes in suspend mode after the specified duration has expired (see *Turning the Unit On and Off* on page 11).

Values are kept in memory when you turn the unit off.

Note: *When the backlight is dimmed, the unit operation is not interrupted. Press any key to return to normal operation.*

To configure the power management settings:

1. Press Menu, select **Setup > Unit**, and then press Select.
2. Use the left/right function arrows until you see **Power**, and then display the pane (F1/F2 key).
3. Use the up/down arrows to go to the **Turn off backlight** or **Turn off unit** section.
4. Use the up/down arrows to select the battery or AC adapter/charger duration list, and then press Select to open the list.
5. With the current duration highlighted, use the up/down arrows to select the desired duration (or **Never**), and then press Select to confirm.

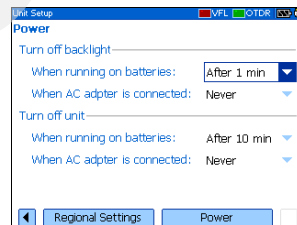

5 **Setting Up Your OTDR**

Installing the Universal Interface (UI)

The UI fixed baseplate is available for connectors with angled (APC) or non-angled (UPC) polishing.

To install a UI connector adapter onto the UI baseplate:

1. Hold the UI connector adapter so the dust cap opens downwards.

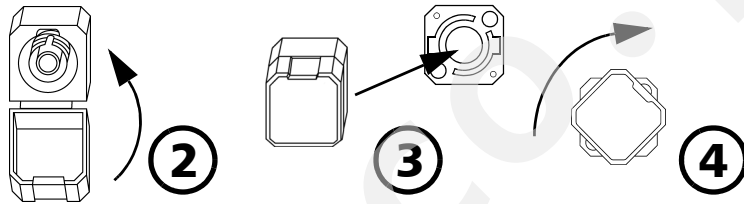

2. Close the dust cap in order to hold the connector adapter more firmly.
3. Align keys and insert the connector adapter into the baseplate.
4. While pushing firmly, turn the connector adapter clockwise on the baseplate to lock it in place.

Cleaning and Connecting Optical Fibers



IMPORTANT

To ensure maximum power and to avoid erroneous readings:

- Always clean fiber ends as explained below before inserting them into the port. IDEAL is not responsible for damage or errors caused by bad fiber cleaning or handling.
- Ensure that your patchcord has appropriate connectors. Joining mismatched connectors will damage the ferrules.

To connect the fiber-optic cable to the port:

1. Carefully align the connector and port to prevent the fiber end from touching the outside of the port or rubbing against other surfaces.

If your connector features a key, ensure that it is fully fitted into the port's corresponding notch.

2. Push the connector in so that the fiber-optic cable is firmly in place, thus ensuring adequate contact.

If your connector features a screwsleeve, tighten the connector enough to firmly maintain the fiber in place. Do not overtighten, as this will damage the fiber and the port.

Note: *If your fiber-optic cable is not properly aligned and/or connected, you will notice heavy loss and reflection.*

Setting General OTDR Parameters

You can set preferences such as:

- **Grid:** You can display or hide the grid appearing on the graph's background. By default, the grid is displayed.
- **Zoom and markers:** You can display or hide the zoom controls as well as the markers appearing on the graph.
- **Automatic zoom on fiber span:** You can set the trace display to show only the portion of the trace that is located between the span start and the span end, in full-trace view. By default, this feature is selected.

Even if the application automatically zooms in on the fiber span, you can adjust the **zoom** manually. You can even zoom in on events located outside the fiber span. For more information on how to use the zoom controls, see *Using Zoom Controls* on page 57.

- **Reference file:** You can enable or disable the selection of a reference trace. A reference trace is used to compare fibers of a same cable, monitor fiber deterioration, or compare fibers before and after installation. This trace appears in red on the graph.
- **Summary pane** (available only with the optional FTTx software package): By default, the **Summary** pane is automatically displayed as soon as an acquisition is complete. You can disable this automatic display (you can always access it via the **Summary** button from the OTDR pane.)
- **Event (fiber) sections:** You can display or hide event (fiber) sections in the **Events** pane, depending on the types of values you want to view. If you display event sections, the **Events** pane will include section length and section attenuation.

For example, by hiding the event (fiber) sections, you can obtain the running total of connector and splice losses instead of having a loss value for the entire link. Information on event sections is also available from the **Trace** pane, in the events table located just below the graph.

To set the general OTDR parameters:

1. Press Menu, select **Setup > OTDR**, and then press Select.
2. Display the **General** pane (F1/F2 key).
3. Use the up/down arrows to highlight the desired item, and then press Select to select it.

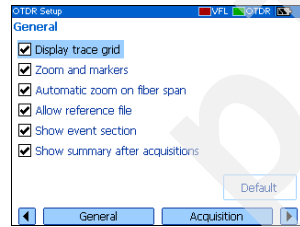

You can press Select one more time to clear the boxes.

To revert to the factory-default settings:

1. Press Menu, select **Setup > OTDR**, and then press Select.
2. From the **General** pane, use the arrows to select **Default**, and then press Select to confirm.

Setting the Acquisition Parameters

You can set parameters such as IOR (group index), backscatter, and helix factor. You can also enable or disable the first connector check.

Setting the IOR, Backscatter, and Helix Factor

Your unit contains default IOR (group index), backscatter, and helix factor values that you can modify if they do not suit your testing needs. You should set the IOR (group index), backscatter, and helix factor before performing tests in order to apply them to all newly acquired traces.

- The index of refraction (IOR) (also known as group index) is used to convert time-of-flight to distance. Having the proper IOR is crucial for all OTDR measurements associated with distance (event position, attenuation, total length, etc.). IOR is provided by the cable or fiber manufacturer.
- The (Rayleigh) backscatter value represents the amount of backscatter in a particular fiber. The backscatter is used in the calculation of ORL and reflectance, and it can usually be obtained from the cable manufacturer.
- The helix factor takes into account the difference between the length of the cable and the length of the fiber inside the cable; it does not vary with wavelengths.

The length of the OTDR distance axis is always equivalent to the physical length of the cable (not the fiber).

To set the IOR, backscatter, and helix factor parameters:

1. Press Menu, select **Setup > OTDR**, and then press Select.
2. Display the **Acquisition** pane (F1/F2 key).
3. Use the up/down arrows to select the wavelength box, and then press Select to open it.
4. Select the wavelength for which you want to modify parameters. Press Select to confirm your choice.
5. Use the arrows to select any of the settings, and then press Select to display the **on-screen keyboard** (for details about using keyboards, see *Using Menus and Keypad* on page 13).



IMPORTANT

Do not change the default backscatter parameter unless you have values provided by the fiber manufacturer. If you set this parameter incorrectly, your reflectance measurements will be inaccurate.

6. Enter the new value and press **OK** (F1/F2 key).

As you enter the value, the application indicates the minimum or maximum value allowed.

Enabling or Disabling the First Connector Check

The first connector check feature is used to verify that the fibers are properly connected to the OTDR. It verifies the injection level and the reflectance of the first connector. It displays a message when a unusually high loss or reflectance occur at the first connection.

You enable or disable this feature for all wavelengths at a time.

To enable or disable the first connector check:

1. Press Menu, select **Setup > OTDR**, and then press Select.
2. Display the **Acquisition** pane (F1/F2 key).
3. Use the up/down arrows to highlight **First connector check**, and then press Select to select it.

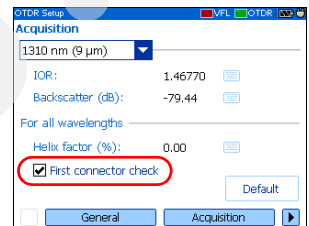

You can press Select one more time to clear the box.

Reverting to Factory-Default Acquisition Settings

You can revert to factory settings at any time. The IOR (group index), backscatter, and helix factor will be reset and the *first connector check* feature will be disabled.

To revert to factory-default settings:

1. Press Menu, select **Setup > OTDR**, and then press Select.
2. From the **Acquisition** pane, use the arrows to select **Default**, and then press Select.
3. When the application prompts you, answer **Yes** (F1/F2 key).

Setting Analysis Parameters

- To define the actual fiber span start, you can set the *launch fiber length*.

When you perform tests with your unit, you connect a launch fiber between your unit and the fiber under test. This is why, by default, the fiber span includes the launch fiber.

When you define the length of the launch fiber, the application sets the fiber span start at the beginning of the fiber under test. Therefore, only events related to the defined fiber span will be taken into account. The application will include the loss caused by the span start event in the displayed values. The span start event will also be taken into account when determining the status (pass/fail) of connector loss and reflectance.

The span start becomes event 1 and its distance reference becomes 0. Events excluded from the fiber span are shaded in the event table, and do not appear in the trace display. The cumulative loss is calculated for the defined fiber span only.

- To optimize event detection, you can set the following detection thresholds:
 - *Splice loss threshold*: To display or hide small non-reflective events.
 - *Reflectance threshold*: To hide false reflective events generated by noise, transform non-harmful reflective events into loss events, or detect reflective events that could be harmful to network and other fiber-optic equipment.
 - *End-of-fiber threshold*: To stop the analysis as soon as an important loss event occurs; for example, an event that could compromise signal transmission down to the end of a network.

To set analysis parameters:

1. Press Menu, select **Setup > OTDR**, and then press Select.
2. Display the **Analysis** pane (F1/F2 key).
3. Use the arrows to select any of the settings, and then press Select to display the **on-screen keyboard** (for details about using keyboards, see *Using Menus and Keypad* on page 13).
4. Enter the new value and press **OK** (F1/F2 key).



As you enter the value, the application indicates the minimum or maximum value allowed.

To revert to the factory-default settings:

1. Press Menu, select **Setup > OTDR**, and then press Select.
2. From the **Acquisition** pane, use the arrows to select **Default**, and then press Select.

Setting Pass/Fail Thresholds

Note: This function is available only with the optional FTTx software package.

You can enable and set pass/fail threshold parameters for your tests.

You can define thresholds to specify acceptable values (in dB) for splice loss, connector loss, reflectance, span loss and span ORL, and this, for each wavelength.

Each time a measurement exceeds a threshold, the result appears in white on a red background in the **Summary** pane preceded by the word “FAIL”, also in red. Values appearing in the event table will also be displayed in white on a red background.

To set pass/fail thresholds:

1. Press Menu, select **Setup > OTDR**, and then press Select.
2. Use the left/right function arrows until you see **Pass/Fail Thresholds**, and then display the pane (F1/F2 key).
3. Press Select to open the wavelength list.
4. Use the up/down arrows to select the desired wavelength. Press Select to confirm your choice.

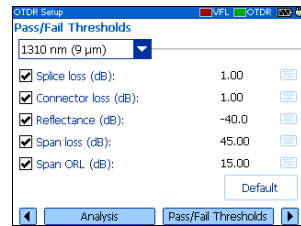

5. Use the up/down arrows to highlight the desired threshold name.
If necessary, press Select to select the check box. If you clear the check box, the application will not use the threshold.
6. Use the arrows to highlight the threshold value, and then press Select to display the **on-screen keyboard** (for details about keyboards, see *Using Menus and Keypad* on page 13).
7. Set the threshold.
As you enter the value, the application indicates the minimum or maximum value allowed.
8. Press **OK** (F1/F2 key) to hide the keyboard.

To revert to the factory-default settings:

1. Press Menu, select **Setup > OTDR**, and then press Select.
2. From the **Pass/Fail Thresholds** pane, use the arrows to select **Default**, and then press Select.
3. When the application prompts you, answer **Yes** (F1/F2 key).

Setting Macrobend Parameters

Note: *This function is available only with the optional FTTx software package.*

Your unit can locate macrobends by comparing the loss values measured at a certain location, for a certain wavelength (for example, 1310 nm) with the loss values measured at the corresponding location, but for a greater wavelength (for example, 1550 nm).

The unit will identify a macrobend when comparing two loss values if:

- Of the two loss values, the greater loss occurred at the greater wavelength.
- AND
- The difference between the two loss values exceeds the defined delta loss value. The default delta loss value is 0.5 dB (which is suitable for most fibers) but you can modify it.

You can also disable macrobend detection.

Note: *Macrobend detection is only possible with singlemode wavelengths.*

To set macroband parameters:

1. Press Menu, select **Setup > OTDR**, and then press Select.
2. Display the **Macroband** pane (F1/F2 key).
3. If necessary, press Select to select the **Display macroband** check box.

If you clear the check box, the application will not detect macrobands.

4. Press Select to open the **Wavelengths** list.
5. Use the up/down arrows to select the desired wavelengths. Press Select to confirm your choice.
6. Use the arrows to highlight the **Delta (dB)** value, and then press Select to display the **on-screen keyboard** (for details about keyboards, see *Using Menus and Keypad* on page 13).
7. Set the delta (loss difference) value.
As you enter the value, the application indicates the minimum or maximum value allowed.
8. Press **OK** (F1/F2 key) to hide the keyboard.

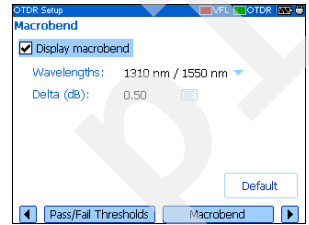

Setting Storage Parameters

Each time you save a trace, the unit suggests a file name based on autonaming settings. After saving a result, the unit prepares the next file name by incrementing the suffix.

File names: maximum of 20 characters for prefix and 3 digits for suffix.

By default, traces are saved in native (.trc) format, but you can configure your unit to save them in Bellcore (.sor) format.

Note: *If you select the Bellcore (.sor) format, the unit will create one trace file per wavelength (for example, TRACE001_1310.sor and TRACE001_1550.sor, if you selected both 1310 nm and 1550 nm for your test). The native format contains all wavelengths in a single trace file.*

To set the autonaming scheme:

1. Press Menu, select **Setup > OTDR**, and then press Select.
2. Use the left/right function arrows until you see **Storage**, and then display the pane (F1/F2 key).
3. Use the up/down arrows to select **File name prefix** or **File name suffix**.
4. Press Select to display the **on-screen keyboard** (for details about using keyboards, see *Using Menus and Keypad* on page 13).
5. Enter the name (prefix) or number (suffix), and then press **OK** (F1/F2 key) to hide the keyboard.

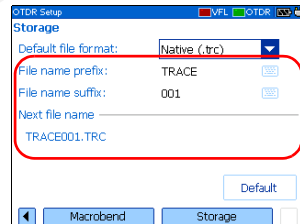

To set the file format:

1. Press Menu, select **Setup** > **OTDR**, and then press Select.
2. Use the left/right function arrows until you see **Storage**, and then display the pane (F1/F2 key).
3. Use the arrows to select **Default file format**, and then press Select to open the list.
4. Use the up/down arrows to select the desired format, and then press Select to confirm.

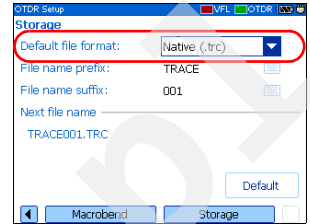
**To revert to the factory-default for file format and autonaming scheme:**

1. Press Menu, select **Setup** > **OTDR**, and then press Select.
2. Use the left/right function arrows until you see **Storage**, and then display the pane (F1/F2 key).
3. Use the up/down arrows to select **Default**, and then press Select to confirm.

6 **Testing Fibers**

The OTDR offers different test modes:

- **Auto:** sets all test parameters, performs tests at the specified wavelengths, and provides complete results.
- **Fault finder:** rapidly locates fiber ends and displays length of the fiber under test. This function is available only with the optional FTTx software package.
- **Manual (advanced):** offers all the tools you need to perform complete OTDR tests and measurements manually and gives you control over all test parameters.
- **Real time:** enables to view sudden changes in the fiber link. In this mode, trace is refreshed instead of averaged.

You can start a test from any pane by pressing the Auto Test key. The unit will use the current parameters. You can stop a test by pressing the Auto Test key one more time.

Your unit may be equipped with two OTDR ports:

- **OTDR SM port:** singlemode port to perform conventional OTDR tests on *dark* fibers.
- **OTDR MM port (optional):** multimode port to perform conventional OTDR tests on *dark* fibers.

OR

- **OTDR SM Live port (optional):** singlemode port with a filtered wavelength to perform troubleshooting tests on *live* fibers.

Testing in Auto Mode

The application will automatically evaluate the best settings according to the fiber link currently connected to the unit (in less than 5 seconds).

By default, fiber characteristics are evaluated each time you start a test. This is particularly useful if you often have to test fiber links of different lengths.

If you prefer, you can set your unit to keep the same settings (range and pulse) for all acquisitions. This could be useful if you need to test several similar fibers (same length) within the same cable. It is always possible to reset the fiber settings later.

If you intend to test at multimode wavelengths, carefully read *Launch Conditions for Multimode Measurements* on page 49.

To acquire traces in Auto mode:

1. Clean the connectors properly (see *Cleaning and Connecting Optical Fibers* on page 22).
2. Connect a launch fiber between the device under test and the OTDR port. If necessary, set the **launch fiber length** (see *Setting Analysis Parameters* on page 28).

If your unit is equipped with two OTDR ports, ensure that you connect the fiber to the appropriate port (OTDR SM, OTDR MM, or OTDR SM Live for filtered wavelength).



CAUTION

Never connect a live fiber to the OTDR SM or OTDR MM port. Any incoming signal greater than -40 dBm will affect the OTDR acquisition. Any incoming signal greater than -20 dBm could damage your OTDR permanently.

3. Press Menu, select **OTDR**, and then press Select.
4. Use the left/right function arrows until you see **Parameters**, and then display the pane (F1/F2 key).
5. Select the test mode as follows:

5a. Use the arrows to select the **OTDR mode** list, and then press Select to open the list.

5b. Use the up/down arrows to select **Auto**, and then press Select to confirm.

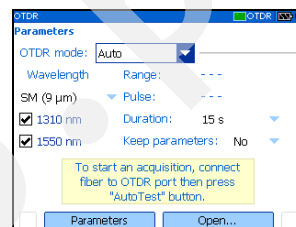

6. Select test wavelengths as follows:
 - 6a.** If your unit supports singlemode and multimode wavelengths, under **Wavelength**, from the list, select the desired fiber type (for C fiber, select 50 μm and for D fiber, select 62.5 μm).
 - 6b.** Use the arrows to select the desired wavelengths and press Select to confirm each selection.
7. Select duration of the acquisition as follows:
 - 7a.** Use the arrows to select the **Duration** list, and then press Select to open it.
 - 7b.** Use the up/down arrows to select the desired duration for the acquisition, and then press Select to confirm.

Testing Fibers

Testing in Auto Mode

8. Specify whether the unit must keep the fiber settings for all acquisitions or not, as follows:
 - 8a. Use the arrows to select the **Keep parameters** list, and then press Select to open it.
 - 8b. If you want the unit to reset the settings for each acquisition, select **No**.

OR

If you want the unit to always use the same parameters, select **Yes**.
 - 8c. Press Select to confirm.

Note: *Even if you configured the unit to keep the parameters, it is possible to reset the fiber settings by selecting **No**, and then starting an acquisition. If desired, you can set back the option to **Yes** to use the new settings for the next acquisitions.*

9. Press Auto Test to start the acquisition.

You can stop the acquisition at any time by pressing Auto Test once again.

Testing in Fault Finder Mode

Note: This function is available only with the optional FTTx software package.

The application offers you a special testing feature to rapidly locate fiber ends. It also displays the length of the fiber under test.

The unit will determine the more appropriate wavelength (singlemode or multimode, depending on your test configuration). Duration of the acquisition is 45 seconds.

If you intend to test at multimode wavelengths, carefully read *Launch Conditions for Multimode Measurements* on page 49.

To acquire traces in Fault finder mode:

1. Clean the connectors properly (see *Cleaning and Connecting Optical Fibers* on page 22).
2. Connect a launch fiber between the device under test and the OTDR port. If necessary, set the [launch fiber length](#) (see *Setting Analysis Parameters* on page 28).

If your unit is equipped with two OTDR ports, ensure that you connect the fiber to the appropriate port (OTDR SM, OTDR MM, or OTDR SM Live for filtered wavelength).



CAUTION

Never connect a live fiber to the OTDR SM or OTDR MM port. Any incoming signal greater than -40 dBm will affect the OTDR acquisition. Any incoming signal greater than -20 dBm could damage your OTDR permanently.

Testing Fibers

Testing in Fault Finder Mode

3. Press Menu, select **OTDR**, and then press Select.
4. Use the left/right function arrows until you see **Parameters**, and then display the pane (F1/F2 key).
5. Select the test mode as follows:
 - 5a. Use the arrows to select the **OTDR mode** list, and then press Select to open it.
 - 5b. Use the up/down arrows to select **Fault finder**, and then press Select to confirm.
6. If your unit supports singlemode and multimode wavelengths, under **Wavelength**, from the list, select the desired fiber type (for C fiber, select 50 μm and for D fiber, select 62.5 μm).
7. Press Auto Test to start the acquisition.

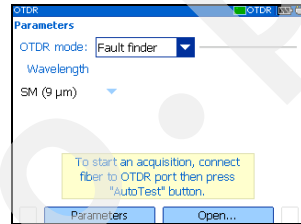

You can stop the acquisition at any time by pressing Auto Test once again.

Testing in Manual (Advanced) Mode

You can set distance range, pulse, and duration of the acquisition in this mode.

Note: *Not all pulse widths are compatible with all wavelengths.*

If you intend to test at multimode wavelengths, carefully read *Launch Conditions for Multimode Measurements* on page 49.

To acquire traces in Manual (Advanced) mode:

1. Clean the connectors properly (see *Cleaning and Connecting Optical Fibers* on page 22).
2. Connect a launch fiber between the device under test and the OTDR port. If necessary, set the **launch fiber length** (see *Setting Analysis Parameters* on page 28).

If your unit is equipped with two OTDR ports, ensure that you connect the fiber to the appropriate port (OTDR SM, OTDR MM, or OTDR SM Live for filtered wavelength).



CAUTION

Never connect a live fiber to the OTDR SM or OTDR MM port. Any incoming signal greater than -40 dBm will affect the OTDR acquisition. Any incoming signal greater than -20 dBm could damage your OTDR permanently.

3. Press Menu, select **OTDR**, and then press Select.
4. Use the left/right function arrows until you see **Parameters**, and then display the pane (F1/F2 key).

Testing Fibers

Testing in Manual (Advanced) Mode

5. Select the test mode as follows:
 - 5a. Use the arrows to select the **OTDR mode** list, and then press Select to open it.
 - 5b. Use the up/down arrows to select **Manual**, and then press Select to confirm.
6. Select test wavelengths as follows:
 - 6a. If your unit supports singlemode and multimode wavelengths, under **Wavelength**, from the list, select the desired fiber type (for C fiber, select 50 μm and for D fiber, select 62.5 μm).
 - 6b. Use the arrows to select the desired wavelengths. Press Select to confirm each selection.
7. Select range as follows:
 - 7a. Use the arrows to select the **Range** list, and then press Select to open the list.
 - 7b. Use the up/down arrows to select the desired distance range, and then press Select to confirm.

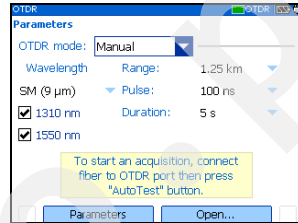

- 8.** Select pulse as follows:
 - 8a.** Use the arrows to select the **Pulse** list and press Select to open the list.
 - 8b.** Use the up/down arrows to select the desired pulse, and then press Select.
- 9.** Select duration of the acquisition as follows:
 - 9a.** Use the arrows to select the **Duration** list, and then press Select to open the list.
 - 9b.** Use the up/down arrows to select the desired duration for the acquisition, and then press Select to confirm.
- 10.** Press Auto Test to start the acquisition.

You can stop the acquisition at any time by pressing Auto Test once again.

Monitoring Fiber in Real Time Mode

You can monitor fiber at one wavelength at a time. You can also switch from Real time mode to Manual mode at any time.

If you intend to test at multimode wavelengths, carefully read *Launch Conditions for Multimode Measurements* on page 49.

To monitor fiber in Real time mode:

1. Clean the connectors properly (see *Cleaning and Connecting Optical Fibers* on page 22).
2. Connect a launch fiber between the device under test and the OTDR port. If necessary, set the **launch fiber length** (see *Setting Analysis Parameters* on page 28).

If your unit is equipped with two OTDR ports, ensure that you connect the fiber to the appropriate port (OTDR SM, OTDR MM, or OTDR SM Live for filtered wavelength).



CAUTION

Never connect a live fiber to the OTDR SM or OTDR MM port. Any incoming signal greater than -40 dBm will affect the OTDR acquisition. Any incoming signal greater than -20 dBm could damage your OTDR permanently.

3. Press Menu, select **OTDR**, and then press Select.
4. Use the left/right function arrows until you see **Parameters** and display the pane (F1/F2 key).

5. Select the test mode as follows:
 - 5a. Use the arrows to select the **OTDR mode** list and press Select to open the list.
 - 5b. Use the up/down arrows to select **Real time**, and then press Select to confirm.
6. Select test wavelengths as follows:
 - 6a. If your unit supports singlemode and multimode wavelengths, under **Wavelength**, from the list, select the desired fiber type (for C fiber, select 50 μm and for D fiber, select 62.5 μm).
 - 6b. Use the arrows to select the desired wavelength. Press Select to select it.
7. Select range as follows:
 - 7a. Use the arrows to select the **Range** list, and then press Select to open the list.
 - 7b. Use the up/down arrows to select the desired distance range, and then press Select to confirm.
8. Select pulse as follows:
 - 8a. Use the arrows to select the **Pulse** list, and then press Select to open the list.
 - 8b. Use the up/down arrows to select the desired pulse, and then press Select to confirm.
9. Press Auto Test to start the acquisition.



Testing Fibers

Monitoring Fiber in Real Time Mode

To deactivate the Real time mode:

If you only want to stop monitoring, press Auto Test once again.

OR

If you are ready to start a test, proceed as follows:

1. Press Exit to exit the **Trace** pane.
2. In the displayed panel, open the **OTDR mode** list, and then select **Manual**.

Launch Conditions for Multimode Measurements

In a multimode fiber network, the attenuation of a signal is highly dependent on the mode distribution (or launch condition) of the source that emits this signal.

In the same way, the attenuation reading performed by any test instrument will also depend on the mode distribution of its light source.

A single light source cannot be conditioned for both 50 μm (50 MMF) and 62.5 μm (62.5 MMF) fibers at the same time:

- A source conditioned for 50 MMF testing will be under-filled for 62.5 MMF testing.
- A source conditioned for 62.5 MMF will be overfilled for 50 MMF testing.

TIA/EIA-455-34A (FOTP34, Method A2) is providing a target launch condition that is obtained when using an overfilled source followed by mandrel-wrap mode filter (five close-wound turns around a mandrel tool of a given diameter).

Your unit has been conditioned for 62.5 MMF testing. However, you can also test with 50 MMF fibers.

Testing Fibers

Launch Conditions for Multimode Measurements

The table on fiber types gives information about tests with the 50 μm and 62.5 μm fibers.

Fiber type	Recommended mode filter	Remarks
50 μm	<p>Perform a five-turn mandrel-wrap (wrapping the patchcord a minimum of five turns around the mandrel tool) on the patchcord connecting the OTDR to the fiber under test.</p> <p>As per FOTP-34:</p> <ul style="list-style-type: none">▶ For fibers with 3 mm jacket: use a mandrel tool with a diameter of 25 mm.▶ For fibers without jacket: use a mandrel tool with a diameter of 22 mm.	<p>Nominal launch conditions are overfilled.</p> <p>Loss measurements can be slightly pessimistic (higher loss) when compared to loss measurements done with a 50 MMF source compliant to FOTP34, Method A2.</p>
62.5 μm	No mode filter required.	Loss measurements similar to those obtained with a power meter and a source that is conditioned according to FOTP34, Method A2.



IMPORTANT

If you test with 50- μm fibers, IDEAL recommends that you use a mode filter (mandrel-wrap). Otherwise, you may obtain results with an excess loss value of 0.1 to 0.3 dB.

7 Managing Test Results

There are many ways to view the results:

- Summary pane
- Events pane
- Trace pane
- Trace Info. (trace information) pane

Summary Pane

This pane is displayed once the test is complete if you selected the corresponding feature (see *Setting General OTDR Parameters* on page 23). You can also select **Summary** (F1/F2 keys).

Pass/Fail status of fiber under test

Length of fiber under test

Tested wavelengths

Information on detected macrobends

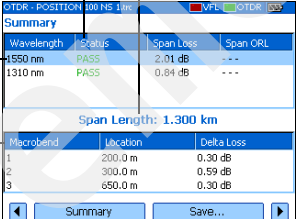

You can select an item with the up/down arrows and press Select to switch to Trace pane.

Wavelength	Status	Span Loss	Span ORL
1550 nm	PASS	2.01 dB	---
1310 nm	PASS	0.64 dB	---

Span Length: 1.300 km

Macrobend	Location	Delta Loss
1	200.0 m	0.30 dB
2	300.0 m	0.59 dB
3	650.0 m	0.30 dB

Managing Test Results

Events Pane

This pane shows the list of events found during the test.

You can select **Events** (F1/F2 keys) to display the pane. Values appearing in white on a red background exceed the defined thresholds.

Wavelength of the displayed trace

Use left/right arrows to switch between the different wavelengths

Event type (see *Description of Event Types* on page 97)

Type	#	Loc. (km)	Loss (dB)	Refl. (dB)	Cumul. (dB)
→	1	0.000	????	-45.0	0.00
↕	2	0.200	0.10	-55.0	0.17
↕	3	0.280	0.10		0.29
↕	4	0.650	0.10		0.52
↕	5	0.800	0.10	-55.0	0.67
↕	6	1.300	99.00	-14.0	0.84

You can select an item with up/down arrows and press Enter to switch to Trace pane.

Trace Pane

You can select **Trace** (F1/F2 keys) to display the pane. Reflectance and loss values appear in white on a red background when they exceed the defined thresholds.

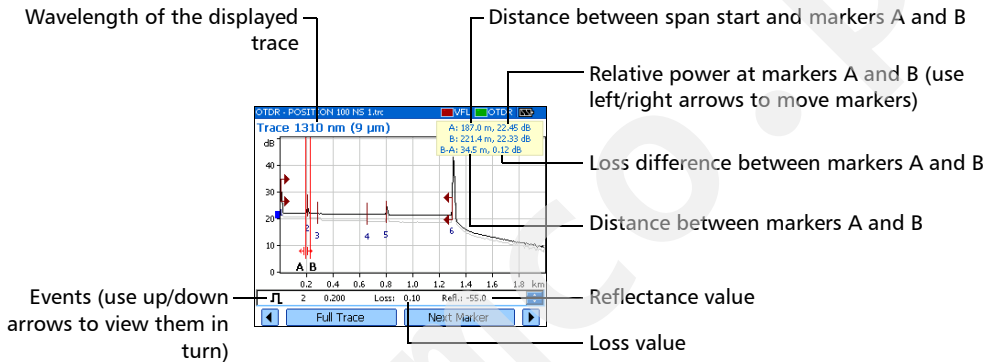

Trace Info. Pane

After acquiring a trace, you might want to view details about the acquisition. You can also include information about the tested fiber and job or add comments. This information is saved along with the trace.

Some of the information is common to all wavelengths (location A and B, cable ID and fiber ID). Some other is specific to the current wavelength (job ID, customer and comments).

If you add or delete information from the **Trace Info.** pane, the common information will be modified for all wavelengths. However, the specific information will be modified for the *current wavelength* only. You will have to add or delete the information manually for other wavelengths.

After entering the required data, you may save the contents (common and generic information) as a template. The next time you start an acquisition, the template is automatically used for all wavelengths, eliminating repetitive documentation operations.

You can select **Trace Info.** (F1/F2 keys) to display the pane.

To document results:

1. Once a trace has been acquired or reopened, press Menu, select **OTDR**, and then press Select.
2. Use the left/right function arrows until you see **Trace Info.**, then display the pane (F1/F2 key).
3. Use the arrows to select the item to modify. Modifiable items are followed by a keyboard icon.
4. Press Select to display the **on-screen keyboard** (for details about using keyboards, see *Using Menus and Keypad* on page 13).
5. Set the name/value, then press **OK** (F1/F2 key) to hide the keyboard.
6. If you want to save the contents as a template, select **Save as Template**.

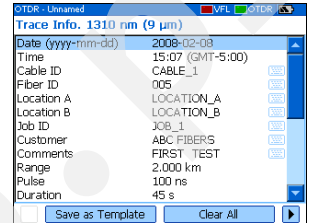

To clear all the information from the editable fields:

Select **Clear All** (F1/F2 key).

You can use markers (A and B) to view the position and level of an event on a trace.

Note: If you do not see the markers on your unit, they are probably *hidden* (see Setting General OTDR Parameters on page 23).

To move a marker:

1. Press Menu, select **OTDR**, and then press Select.
2. Use the left/right function arrows until you see **Trace**, and then display the pane (F1/F2 key).
3. Use **Next Marker** (F1/F2 key) to select the marker to move.
4. Use the left and right arrows to move the marker along the trace.

If a marker is moved too close to another, both will move together to ensure a minimum distance between them.

5. When you have finished, use the left/right function arrows until you see **Exit**, and then close the pane (F1/F2 key).

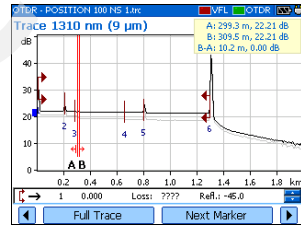

Using Zoom Controls

As soon as you select one of the zoom controls to change the scale of the graph, a magnifying glass icon appears. When the scale changes, the trace is always centered on the area surrounding the magnifying glass icon.

You can let the unit automatically adjust the zoom on the currently selected event or zoom in on or out of the graph using manual zoom. You can also return to the original graph scale.

Note: *If you want the application to automatically zoom on the defined fiber span, see [Setting General OTDR Parameters](#) on page 23.*

Note: *If you do not see the zoom controls on your unit, they are probably [hidden](#) (see [Setting General OTDR Parameters](#) on page 23).*

To automatically zoom in on the selected event:

1. Press Menu, select **OTDR**, and then press Select.
2. Use the left/right function arrows until you see **Trace**, and then display the pane (F1/F2 key).
3. Press Select to zoom in. Press Select one more time to go to the second level of zoom.

You can switch between the two levels of zoom by pressing Select as needed.

Managing Test Results

Using Zoom Controls

To view specific portions of the graph:

1. Press Menu, select **OTDR**, and then press Select.
2. Use the left/right function arrows until you see **Trace**, and then display the pane (F1/F2 key).
3. Display the **Manual Zoom** pane (F1/F2 key).
4. Use the arrows to move the magnifying glass icon to the area where you want to adjust the zoom.
5. Select the zoom parameters.

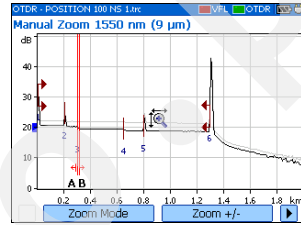

- Press **Zoom Mode** (F1/F2 key) as many times as needed to select the desired type of zoom.

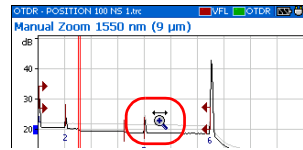

Zoom along horizontal axis only

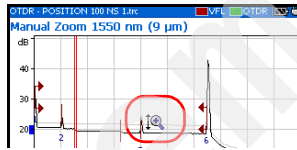

Zoom along vertical axis only

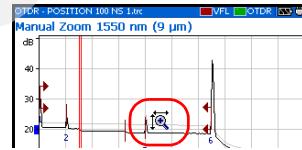

Zoom along both axes

- Press **Zoom +/-** (F1/F2 key) to switch from zoom-in to zoom-out mode and vice versa.
6. Press Select as many times as needed.
 7. When you have finished:

Use the left/right function arrows until you see **Exit**, then close the pane (F1/F2 key).

OR

Press Exit to close the pane.

To revert to the complete graph view:

1. From the **Trace** pane, use the left/right function arrows until you see **Full Trace**.
2. Press **Full Trace** (F1/F2 key) to revert to complete graph view.

Note: *If the Automatic zoom on fiber span feature is selected in the OTDR setup, the application will zoom in between span start and span end.*

Printing Test Results

With a *Printek 2"* printer, you can print results directly from the IDEAL OTDR.

Note: *You cannot print ping or trace route test results from the IDEAL OTDR.*

The unit communicates with the printer through its infrared port.

To print test results:

1. **Select the printer** (see *Selecting a Printer* on page 19).
2. Once a trace has been acquired or reopened, press **Menu**, select **OTDR**, and then press **Select**.
3. Select **Print** (F1/F2 key).



Wavelength	Status	Span Loss	Span ORL
1550 nm	PASS	2.01 dB	---
1310 nm	PASS	0.84 dB	---

Span Length: 1.300 km

Save... Print

Managing Test Results

Opening Trace Files

You can open a maximum of two files at a time: a main trace and a reference trace (if the corresponding feature is selected).

Your unit can display traces saved in native (.trc) and Bellcore (.sor) formats.

To open trace files:

1. Press Menu, select **OTDR**, and then press Select.
2. Use the left/right function arrows until you see **Open**, then display the pane (F1/F2 key).
3. If you enabled the reference trace feature (see *Setting General OTDR Parameters* on page 23), use the up/down arrows to select the selection button corresponding to the desired trace. Press Select to view the browser.

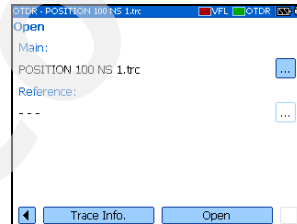

Note: If desired, press **New Folder** to *create folders* (for more information, see *Creating Folders* on page 63).

4. Use the up/down arrows to navigate in the list. Use the right arrow to open a folder. Highlight the desired file and press **Open** (F1/F2 key).
5. If you enabled the reference trace feature, repeat steps 3 and 4 with the other file.

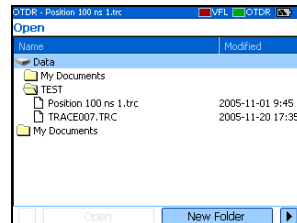

Saving Files

Each time you save a new file, the unit suggests a file name based on autonaming settings.

- **Trace files:** By default, traces are saved in native (.trc) format, but you can configure your unit to save them in Bellcore (.sor) format.

For more information on storage settings, see *Setting Storage Parameters* on page 34.

- **Image files:** By default, images are saved in .jpg format, but you can configure your unit to save them in .bmp format.

For more information on storage settings, see *Setting Storage Parameters for Images* on page 93.

- **Ping files.** For information on storage settings, see *Setting Storage Parameters for Ping Tests* on page 98.

- **Trace route files.** For more information on storage settings, see *Setting Storage Parameters for Trace Route Tests* on page 99.

Managing Test Results

Saving Files

To save files:

1. Use the left/right function arrows until you see **Save**, and then display the pane (F1/F2 key).
 2. If desired, press **New Folder** to create folders (for more information, see *Creating Folders* on page 63).
 3. If you want to modify the storage location, proceed as follows:
 - 3a. Press the up arrow to access the file list.
 - 3b. Use the up/down arrows to highlight the desired folder.
 - 3c. Press Select to transfer the new path to the box at the bottom of the screen.
 4. If you want to modify the file name, press Select to display the **on-screen keyboard** (for details about using keyboards, see *Using Menus and Keypad* on page 13).
 5. Enter the new name and press **OK** (F1/F2 key).
- The unit will keep the last storage path defined.

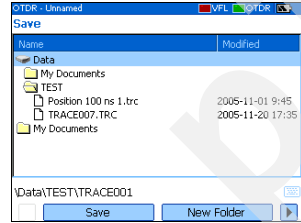

Checking Available Memory

You can save up to 500 OTDR traces in the unit's memory.

To view the available memory on your unit:

1. Press Menu, select **File Manager/Info.** > **File Manager**, and then press Select.
2. Use the arrows to select either a storage medium or a folder to view both used space and free space.

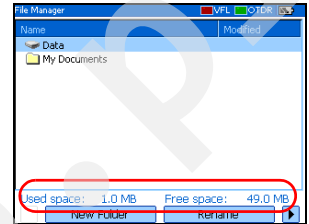

Creating Folders

For easier data management, you can create folders from several panes in the application.

If you prefer, you can [copy folders](#) instead, see *Copying, Renaming, or Deleting Files and Folders* on page 64.

To create folders:

1. From the current window, select the location where you want to create a folder as follows:
 - 1a. Find the folder or disk:

Use the up/down arrows to navigate in the list and the right arrow to open a folder or explore a disk.
 - 1b. Highlight the desired folder or disk.
2. Select **New Folder** (F1/F2 key).
3. Enter the new name and press **OK** (F1/F2 key).

Managing Test Results

Copying, Renaming, or Deleting Files and Folders

Copying, Renaming, or Deleting Files and Folders

You can copy, rename, or delete folders or single files directly from your unit.

To copy files:

1. Press Menu, select **File Manager/Info.** > **File Manager**, and then press Select.
2. Select the desired file or folder as follows:
 - 2a. Find the file or folder using the up/down arrows to navigate in the list and the right arrow to open a folder.
 - 2b. Highlight the desired file or folder and press Select to select it.
3. Select **Copy To** (F1/F2 key).

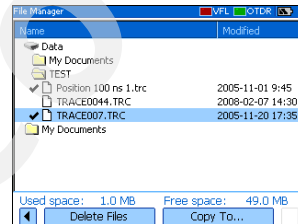

Note: *If the Copy To feature is not available, it is probably because the item is not selected. Press Enter to select it.*

4. Paste the file or folder as follows:
 - 4a. Find the destination folder using the up/down arrows to navigate in the list of folders and the right arrow to open a folder.
 - 4b. Highlight the desired location and press either **OK** (F1/F2 key) or **Select** to complete the process.

To rename files or folders:

1. Press Menu, select **File Manager/Info.** > **File Manager**, and then press Select.
2. Select the desired file or folder as follows:
 - 2a. Find the file or folder using the up/down arrows to navigate in the list and the right arrow to open a folder.
 - 2b. Highlight the desired file or folder, but do not select it (by pressing Enter).
3. Select **Rename** (F1/F2 key).

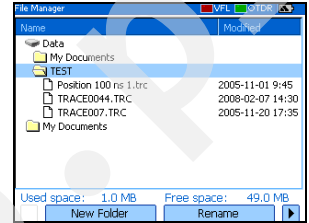

Note: If the **Rename** feature is not available, it is probably because the item is selected. Simply press Enter to cancel the selection.

4. Enter the new name and press **OK** (F1/F2 key).

To delete files:

1. Press Menu, select **File Manager/Info.** > **File Manager**, and press Select.
2. Select the file or folder as follows:
 - 2a. Find the file or folder using the up/down arrows to navigate in the list and the right arrow to open a folder.
 - 2b. Highlight the desired file or folder and press Select to select it.
3. Select **Delete Files** (F1/F2 key).

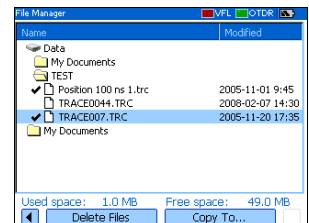

Note: If the **Delete Files** feature is not available, it is probably because the item is not selected. Press Enter to select it.

4. Answer **Yes** (F1/F2 key) to confirm the deletion.



Managing Test Results

Transferring Results to a Computer

Transferring Results to a Computer

You can transfer files from your OTDR to a USB memory drive, or a computer. You can also transfer data from a storage device or from a computer to your OTDR.

Your OTDR is equipped with two types of USB ports:

- USB host port (type A connector)  to connect USB memory drives
- USB secondary port (type B connector)  to transfer data directly between your OTDR and a computer using a USB cable.



IMPORTANT

To avoid any problems and prevent malfunctioning, use only the USB drives approved by IDEAL.

To transfer files or folders between your unit and a USB memory drive:

1. Connect the USB memory drive to the USB host port.
2. Press Menu, select **File Manager/Info.** > **File Manager**, and then press Select.

The list of drives and folders should include the memory drive (**Removable Disk**).

You can now manage your files and folders as you wish.

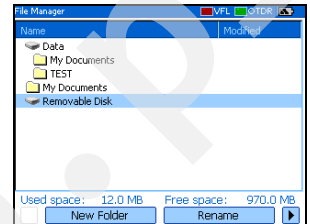

Note: You can connect a memory drive even while File Manager is open.



IMPORTANT

Transferred files are **not** automatically deleted from your unit.

3. When you have finished, remove the card or the memory drive.

Managing Test Results

Transferring Results to a Computer

To transfer files or folders between your unit and a computer:



IMPORTANT

You must install Microsoft ActiveSync on the computer you want to use with your OTDR. Otherwise, you will not be able to transfer data.

Before connecting your unit to a computer, you must install the required software on the computer. For more information on the installation, refer to the Release Notes on the installation CD.

1. If it is not already done, install Microsoft ActiveSync 4.1 or later (available from the installation CD).
Follow the instructions given on the screen.
2. Connect the provided USB cable to the computer (type A connector) and your unit (type B connector).

Note: *The computer and your unit do not need to be off when you connect the cable.*

3. Once ActiveSync indicates that the computer and the OTDR are connected, right-click the ActiveSync icon then select **Explore** to access the files and folders stored on your OTDR.

OR

On the computer desktop, double-click **My Computer**. Double-click **Mobile Device** to access the files and folders stored on your unit.

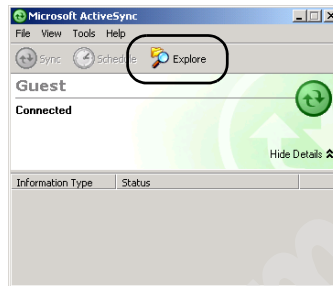

You can now manage your files and folders as you wish.

4. When you have finished, close the **Mobile Device** window and disconnect the USB cable.

8 **Using Your OTDR as a Light Source**

You can use your OTDR as a light source. The source signal uses the OTDR ports. This signal can be:

- continuous (constant power over the temperature range, but about 3 dB lower than maximum)
- or
- modulated (270 Hz, 1 kHz or 2 kHz, 270 Hz blink, 1 kHz blink or 2 kHz blink).

Note: *When you switch wavelengths, the modulation remains the same.*



WARNING

When a source is active, its port emits invisible laser radiation. Avoid exposure and do not stare directly into the beam. Ensure that any unused port is properly protected with a cap.

Using Your OTDR as a Light Source

Activating/Deactivating a Light Source

Activating/Deactivating a Light Source

The **Power Meter** pane remains displayed when you use the source.

The source status is indicated with a LED in the status bar and with the **Active** indicator under the keypad.

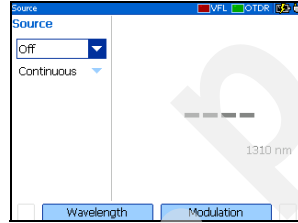

Note: The **Active** indicator always shows the source, VFL, or OTDR port status (even in FIP or idle mode).

To activate the light source:

1. Connect the fiber under test to the source port (see *Cleaning and Connecting Optical Fibers* on page 22).

If your unit is equipped with two OTDR ports, ensure that you connect the fiber to the appropriate port, depending on the wavelength you intend to use.

2. Press Menu, select **Source**, and then press Select.
3. Press **Wavelength** (F1/F2 key) to activate each available source in turn.

OR

Use the arrows to open the wavelength/status list and select the desired wavelength.

To deactivate the light source:

Press **Wavelength** (F1/F2 key) until you get past the last source. The list displays **Off**.

OR

Use the arrows to open the wavelength list and select **Off**.

Modulating the Source Signal

When you turn the unit on, the signal is continuous (unmodulated) by default. When you switch wavelengths, the modulation remains the same. Modulation is indicated in the **Source** pane.

Available values are: Continuous, 270 Hz, 1 kHz, 2 kHz, 270 Hz blink, 1 kHz blink, or 2 kHz blink.

To change the signal modulation:

1. Activate the source if you want.
2. Press **Modulation** (F1/F2 key) to switch between available modulations.

OR

Use the arrows to open the list and select the desired modulation.

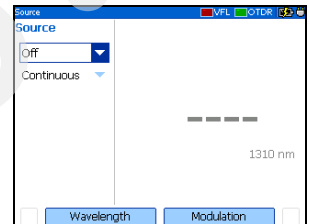

9 **Maintenance**

To help ensure long, trouble-free operation:

- Always clean fiber-optic connectors before using them.
- Keep the unit free of dust.
- Clean the unit casing and front panel with a cloth slightly dampened with water.
- Store unit at room temperature in a clean and dry area. Keep the unit out of direct sunlight.
- Avoid high humidity or significant temperature fluctuations.
- Avoid unnecessary shocks and vibrations.
- If any liquids are spilled on or into the unit, turn off the power immediately and let the unit dry completely.



WARNING

Use of controls, adjustments, and procedures for operation and maintenance other than those specified herein may result in hazardous radiation exposure.

Cleaning UI Connectors

Regular cleaning of UI connectors will help maintain optimum performance. There is no need to disassemble the unit.



IMPORTANT

If any damage occurs to internal connectors, the module casing will have to be opened and a new calibration will be required.

To clean UI connectors:

1. Remove the UI from the instrument to expose the connector baseplate and ferrule.

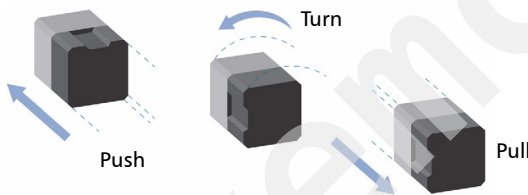

2. Moisten a 2.5 mm cleaning tip with *one drop* of isopropyl alcohol (alcohol may leave traces if used abundantly).
3. Slowly insert the cleaning tip into the UI adapter until it comes out on the other side (a slow clockwise rotating movement may help).

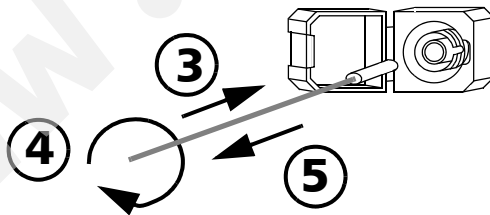

4. Gently turn the cleaning tip one full turn, then continue to turn as you withdraw it.

5. Repeat steps 3 to 4 with a dry cleaning tip.

Note: *Make sure you don't touch the soft end of the cleaning tip.*

6. Clean the ferrule in the connector port as follows:

6a. Deposit *one drop* of isopropyl alcohol on a lint-free wiping cloth.



IMPORTANT

Isopropyl alcohol may leave residues if used abundantly or left to evaporate (about 10 seconds).

Avoid contact between the tip of the bottle and the wiping cloth, and dry the surface quickly.

6b. Gently wipe the connector and ferrule.

6c. With a dry lint-free wiping cloth, gently wipe the same surfaces to ensure that the connector and ferrule are perfectly dry.

6d. Verify connector surface with a portable fiber-optic microscope or video inspection probe.



WARNING

Verifying the surface of the connector **WHILE THE UNIT IS ACTIVE** WILL result in permanent eye damage.

7. Put the UI back onto the instrument (push and turn clockwise).
8. Throw out cleaning tips and wiping cloths after one use.

Recharging Main Batteries

The charge status of both batteries is shown on the **Unit Information** pane (press **Menu**, select **File Manager/Info. > Information**, and then press **Select**).

The charge status is also indicated by the LEDs on the left side of the unit:

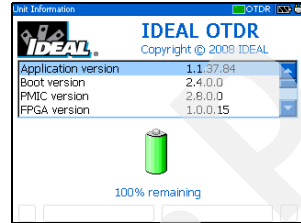

Status LED	Battery Charge Status
Green	Fully charged
Red	Charging
Yellow	Error



IMPORTANT

- ▶ Batteries are not charged at the factory. Fully charge them (about 3 hours if unit is off) before using the unit for the first time.
- ▶ Batteries function and charge properly between 0 °C and 45 °C (32 °F and 113 °F). Batteries will not charge if the temperature is below -10 °C (14 °F) or above 45 °C (113 °F).
- ▶ Never store at temperatures above 60 °C (140 °F).
- ▶ Charge only with specified charger.

To recharge the main batteries:

Connect the unit to a power outlet (or car outlet) using the AC adapter/charger. The charge cycle will start and end automatically.

Replacing Batteries

As soon as you remove the battery compartment door, the unit will turn itself off.



WARNING

Do not throw batteries into fire or water and do not short-circuit the batteries' electrical contact. Do not disassemble.

To replace main batteries:

- 1.** Open the battery compartment door located at the back of the unit.
- 2.** Lift the mobile part of the battery lock and turn it 90° clockwise.

The base of the battery lock will fit in the groove between the two batteries.

- 3.** Replace both batteries, respecting the polarity.
- 4.** Lift the mobile part of the battery lock and turn it 90° counterclockwise to secure the batteries in place.

For optimum reliability, put the battery lock back in place, as shown in the figure above.

- 5.** Close the battery compartment door; you cannot turn on the unit if the battery door is open.

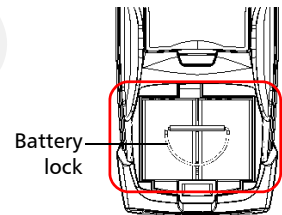

Recalibrating the Unit

Manufacturing and service center calibrations are based on the ISO/IEC 17025 Standard, which states that calibration documents must not contain a recommended calibration interval, unless this has been previously agreed upon with the customer.

Validity of specifications depends on operating conditions. For example, the calibration validity period can be longer or shorter depending on the intensity of use, environmental conditions and unit maintenance. You should determine the adequate calibration interval for your unit according to your accuracy requirements.

Under normal use, IDEAL recommends calibrating your unit every year.

Upgrading the IDEAL OTDR Software

The necessary software has been preinstalled and configured at the factory. However, you may have to upgrade the software when new versions become available.

For the upgrade, you will need:

- the installation CD (includes ActiveSync installation kit)
- a computer equipped with a USB port; Windows 2000 or Windows XP must be installed on the computer.
- an IDEAL unit
- a USB cable



IMPORTANT

You must install Microsoft ActiveSync on the computer you want to use with your OTDR. Otherwise, you will not be able to upgrade the software.

Before connecting your unit to a computer, you must install the required software on the computer. For more information on the installation, refer to the Release Notes on the installation CD.

Maintenance

Upgrading the IDEAL OTDR Software

To upgrade the software:

- 1.** Turn on the computer and insert the installation CD in the CD-ROM drive.
- 2.** Follow the on-screen instructions. All the necessary components, including ActiveSync, will be installed on your computer.
- 3.** Once the installation is complete, turn on the OTDR.
- 4.** Connect the provided USB cable to the computer (type A end) and your OTDR (type B end). ActiveSync automatically opens and establishes the connection.
- 5.** From the computer, on the Windows taskbar, click the **Start** button, and then go to **Programs > IDEAL > IDEAL Handheld Instrument Software Manager**.
- 6.** Use **Add Programs** to install new versions and follow the on-screen instructions.

For more information, refer to the online help of the Handheld Instrument Software Manager (from the **Help** menu).
- 7.** When the installation is complete, disconnect the USB cable.

Recycling and Disposal (Applies to European Union Only)



Recycle or dispose of your product (including electric and electronic accessories) properly, in accordance with local regulations. Do not dispose of it in ordinary garbage receptacles.



This equipment was sold after August 13, 2005 (as identified by the black rectangle).

- Unless otherwise noted in a separate agreement between IDEAL and a customer, distributor, or commercial partner, please return the equipment either to IDEAL or the business partner at which the equipment has been purchased.
- Except for reasons of safety or environmental benefit, equipment manufactured by IDEAL, under its brand name, is generally designed to facilitate dismantling and reclamation.

For complete recycling/disposal procedures and contact information, visit the IDEAL Web site at www.europe.idealindustries.de.

10 Troubleshooting

Solving Common Problems

The table following presents common problems and their solution.

Problem	Possible Cause	Solution
Impossible to turn on unit.	<ul style="list-style-type: none">▶ You did not press Pwr long enough.▶ Main batteries discharged.▶ Battery compartment door is open.▶ One of the two batteries is missing.▶ Weather too cold.	<ul style="list-style-type: none">▶ Press Pwr for 2 seconds.▶ Charge batteries by connecting the AC adapter/charger.▶ Close battery compartment door.▶ Insert 2 batteries and replace battery compartment door.
The display is almost blank when you turn on the unit.	Brightness may need some adjustment.	Press  to adjust brightness properly.
Batteries do not charge as expected.	<ul style="list-style-type: none">▶ Temperature is too high.▶ Battery is incorrectly connected.	<ul style="list-style-type: none">▶ Ensure temperature is within specifications.▶ Ensure battery is connected properly.
A battery status LED is yellow.	Battery is defective.	Contact IDEAL or replace the battery.
The application displays a message indicating that a “Non-resolved fiber end” event has been found.	The fiber under test is too long.	Ensure that the fiber under test is shorter than the maximum length the OTDR can measure.

Troubleshooting

Solving Common Problems

Problem	Possible Cause	Solution
The unit is not responding.		<p>Shut down the unit by pressing Pwr and holding it down.</p> <p>You will hear a first beep; release the key after you hear a second beep.</p> <p>Turn the unit on again to reset it.</p>
You can no longer view the OTDR application.		<p>Shut down the unit by pressing Pwr and holding it down.</p> <p>You will hear a first beep; release the key after you hear a second beep.</p> <p>Press simultaneously Pwr, Exit, and Menu and hold them a few seconds until you see Maintenance Mode on the screen. It may take a few seconds before the maintenance menu appears.</p> <p>Use the up/down arrows to highlight Restore System Disk, and then press Select.</p> <p>When the application prompts you to confirm deletion of all data, use the up/down arrows to highlight Yes, and then press Select.</p> <p>Your unit will restart automatically when update is complete.</p>

Problem	Possible Cause	Solution
<p>The application displays a message indicating that a “live fiber error” occurred.</p>	<p>Light has been detected on the OTDR port during the acquisition or while you were monitoring a fiber in real-time mode.</p>	<p>Disconnect the fiber from the OTDR port. Press OK to close the message.</p> <p>Start another acquisition without any fiber connected to the OTDR. The message about live fiber error should not appear and the OTDR trace should look “normal”.</p> <p>If you still see the message about live fiber error even if no fiber is connected to the OTDR, contact IDEAL.</p> <p>Never connect a live fiber to the OTDR port. Any incoming signal greater than -40 dBm will affect the OTDR acquisition. Any incoming signal greater than -20 dBm could damage your OTDR permanently.</p>

Obtaining Online Help

Context-sensitive help is conveniently available at all times to guide you through the use of your unit.

To obtain online help about the current function:

On the unit keypad, press the ? key.

To navigate in the online help:

- Use up/down arrows to scroll through help page.
- Use left/right arrows to switch between hyperlinks (underlined items) and press Select to link to selected help page.
- Press **Next Page** to switch between available topics in sequence.
- Press **Help Menu** to display the main menu of help topics.
- On the unit keypad, press Exit to return to the pane.

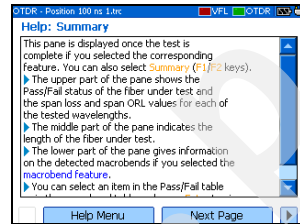

Customer Support and Technical Assistance

To obtain after-sales service or technical support for this product, contact IDEAL at one of the following numbers. All inquiries regarding service, calibration and technical assistance should be directed to the Customer Service department:

IDEAL Industries, Inc.

Corporate Headquarters
Becker Place
Sycamore, IL 60178, USA

Tel.: 815-895-5181 / 800-435-0705
Fax: 815-895-9470 / 800-533-4483
Ideal@idealindustries.com

**North and South America
Sales and Service**

9145 Balboa Avenue
San Diego, CA 92123, USA

Tel: 858-279-2955 / 800-854-2708
Fax: 858-278-5141

IDEAL Industries (Canada), Inc.

33 Fuller Road
Ajax, Ontario L1S 2E1, Canada

Tel.: 905-683-3400 / 800-527-9105
Fax: 905-683-0209
Ideal_Canada@idealindustries.com

IDEAL Industries (U.K.) Ltd.

225 Europa Boulevard
Gemini Business Park
Warrington, Cheshire, WA5 7TN, England

Tel.: +44 (0) 1925 444446
Fax: +44 (0) 1925 445501
Ideal_UK@idealindustries.com

IDEAL Industries GmbH

Gutenbergstrasse 10
D-85737 Ismaning, Germany

Tel.: +49-89-...
Fax: +49-89-99686-111
Ideal_Germany@idealindustries.com

IDEAL Industries (France)

Parc Burospace
Bâtiment 7
Route de Gisy
91571 Bièvres Cedex, France

Tel.: 01 69 35 54 76
Fax: 01 60 19 00 48
Frederic.Fonfrede@idealindustries.com

Troubleshooting

Customer Support and Technical Assistance

IDEAL Industries Australia

Level 6 / 75-85 Elizabeth St
Sydney, NSW 2000 Australia
GPO BOX 5124
Sydney, NSW 2001, Australia

Tel.: 1300 765 800 / 61300 765 800
Fax: 1300 765 801 / 61300 765 801
Mobile: 0405 123 100 / 61405 123 100
Ideal_Australia@idealindustries.com

IDEAL Industries China L.L.C

Unit 505, Tower W1, The Towers,
Oriental Plaza
No. 1 East Chang An Avenue,
Dong Cheng District
Beijing, 100738, China

Tel.: 86-10... / 86-10...
Fax: 86-10-8518-3143
Ideal_China@idealindustries.com

IDEAL Industries Brasil Ltda.

América Business Park
Av. Marginal do Rio Pinheiros, 5200 - 201/F
São Paulo - SP, Brasil

Tel.: +55-1... (main) /
+55-11-3759-8776 (tech support)
Fax: +55-11-3759-8775
Ideal_Brazil@idealindustries.com

To accelerate the process, please have information such as the name and the serial number (see the product identification label), as well as a description of your problem, close at hand.

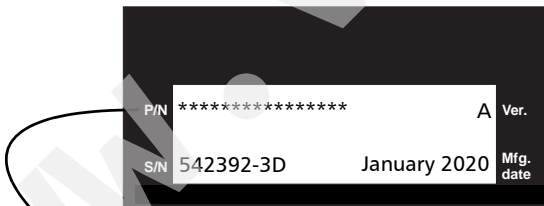

33-960-X

You may also be requested to provide the firmware or software version numbers.

To find out the firmware or software version numbers:

1. Press Menu, select **File Manager/Info.** > **Information**, and press Select.
2. Press **About** (F1/F2 key).

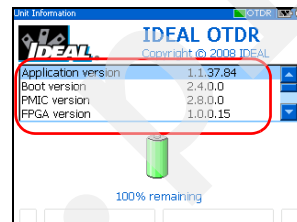

Transportation

Maintain a temperature range within specifications when transporting the unit. Transportation damage can occur from improper handling. The following steps are recommended to minimize the possibility of damage:

- Pack the unit in its original packing material when shipping.
- Avoid high humidity or large temperature fluctuations.
- Keep the unit out of direct sunlight.
- Avoid unnecessary shocks and vibrations.

11 **Warranty**

General Information

IDEAL warrants this equipment against defects in material and workmanship for a period of one year from the date of shipment. Any instrument found to be defective during the warranty period may be returned, transportation pre-paid, to the factory for repair without charge.

This warranty does not apply to instruments that have been repaired or altered by an unauthorized person, or which have been subjected to misuse, negligence, or accident, or to instruments on which the Calibration/Warranty seal is broken.

THIS WARRANTY IS IN LIEU OF ALL OTHER WARRANTIES EXPRESSED, IMPLIED, OR STATUTORY, INCLUDING, BUT NOT LIMITED TO, THE IMPLIED WARRANTIES OF MERCHANTABILITY AND FITNESS FOR A PARTICULAR PURPOSE. IN NO EVENT SHALL IDEAL BE LIABLE FOR SPECIAL, INCIDENTAL, OR CONSEQUENTIAL DAMAGES.

Liability

IDEAL shall not be liable for damages resulting from the use of the product, nor shall be responsible for any failure in the performance of other items to which the product is connected or the operation of any system of which the product may be a part.

IDEAL shall not be liable for damages resulting from improper usage or unauthorized modification of the product, its accompanying accessories and software.

Warranty

Exclusions

Exclusions

IDEAL reserves the right to make changes in the design or construction of any of its products at any time without incurring obligation to make any changes whatsoever on units purchased. Accessories, including but not limited to fuses, pilot lamps, batteries and universal interfaces (UI) used with IDEAL products are not covered by this warranty.

This warranty excludes failure resulting from: improper use or installation, normal wear and tear, accident, abuse, neglect, fire, water, lightning or other acts of nature, causes external to the product or other factors beyond the control of IDEAL.

Service and Repairs

IDEAL commits to providing product service and repair for five years following the date of purchase.

To send any equipment for service or repair:

1. Call one of IDEAL's authorized service centers (see *IDEAL Service Centers Worldwide* on page 96). Support personnel will determine if the equipment requires service, repair, or calibration.
2. If equipment must be returned to IDEAL or an authorized service center, support personnel will issue a repair authorization number and provide an address for return.
3. If possible, back up your data before sending the unit for repair.
4. Pack the equipment in its original shipping material. Be sure to include a statement or report fully detailing the defect and the conditions under which it was observed.
5. Return the equipment, prepaid, to the address given to you by support personnel. Be sure to write the repair authorization number on the shipping slip. *IDEAL will refuse and return any package that does not bear a valid number.*

Note: *A test setup fee will apply to any returned unit that, after test, is found to meet the applicable specifications.*

After repair, the equipment will be returned with a repair report. If the equipment is not under warranty, you will be invoiced for the cost appearing on this report. IDEAL will pay return-to-customer shipping costs for equipment under warranty. Shipping insurance is at your expense.

Warranty

IDEAL Service Centers Worldwide

IDEAL Service Centers Worldwide

If your product requires servicing, contact your nearest authorized service center.

www.vemco.pl

A **Description of Event Types**

This section describes all types of events that may appear in the events table generated by the application. Here is a guide to the descriptions:

- Each type of event has its own symbol.
- Each type of event is represented by a graph of a fiber trace, which illustrates the power reflected back toward the source as a function of distance.
- An arrow points to the location of the event type in the trace.
- Most graphs show one complete trace; that is, an entire acquisition range.
- Some graphs show only a portion of the entire range to view events of interest more closely.

Span Start

The Span Start of a trace is the event that marks the beginning of the fiber span. By default, the Span Start is placed on the first event of a tested fiber (typically the first connector of the OTDR itself).

Span End

The Span End of a trace is the event that marks the end of the fiber span. By default, the Span End is placed on the last event of a tested fiber, and is called the end-of-fiber event.

You can also make another event the end of the span you want to focus your analysis on. This will set the end of the events table at a specific event along the trace.

Description of Event Types

Continuous Fiber

Continuous Fiber ----

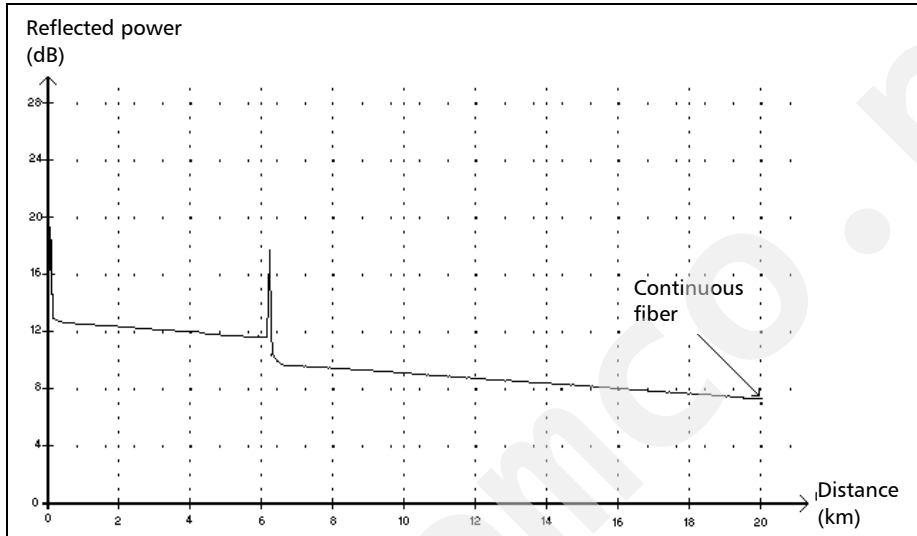

This event indicates that the selected acquisition range was shorter than the fiber length.

- The fiber end was not detected because the analysis process ended before reaching the end of the fiber.
- The acquisition distance range should therefore be increased to a value greater than the fiber length.
- There is no loss or reflectance specified for continuous fiber events.

End of Analysis →

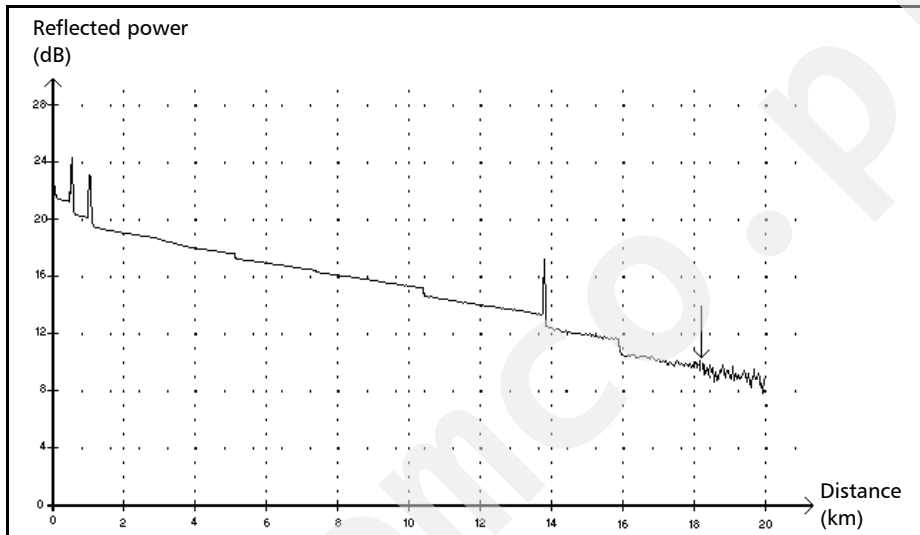

This event indicates that the pulse width used did not provide enough dynamic range to get to the end of the fiber.

- The analysis ended before reaching the end of the fiber because the signal-to-noise ratio was too low.
- The pulse width should therefore be increased so the signal reaches the end of the fiber with a sufficient signal-to-noise ratio.
- There is no loss or reflectance specified for end-of-analysis events.

Description of Event Types

Non-Reflective Event

Non-Reflective Event

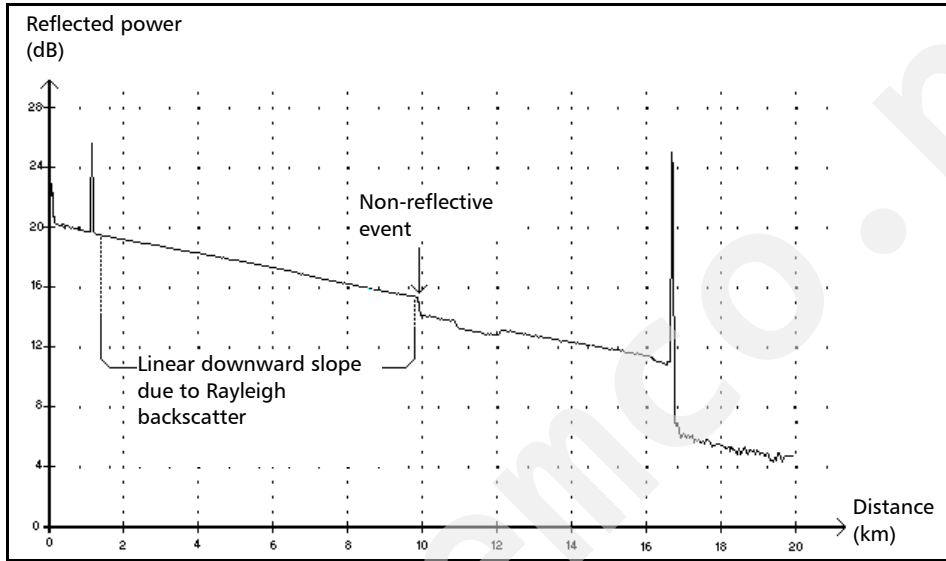

This event is characterized by a sudden decrease in the Rayleigh backscatter signal level. It appears as a discontinuity in the downward slope of the trace signal.

- This event is often caused by splices, macrobends, or microbends in the fiber.
- A loss value is specified for non-reflective events. There is no reflectance specified for this type of event.
- If you set thresholds, the application indicates a non-reflective event in the events table, whenever a value exceeds the loss threshold (see *Setting Pass/Fail Thresholds* on page 30).

Positive Event

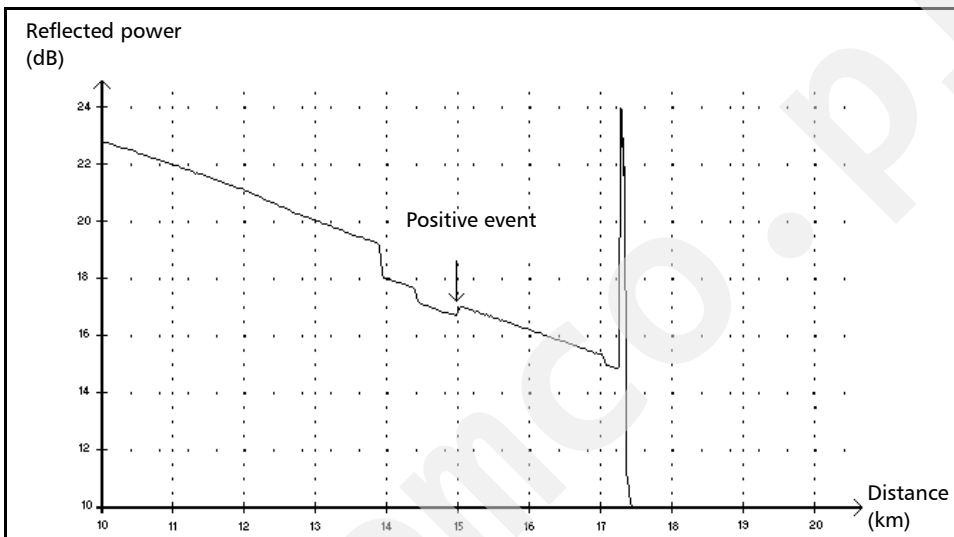

This event indicates a splice with an apparent gain, due to the junction of two fiber sections having different fiber backscatter characteristics (backscatter and backscatter capture coefficients).

- A loss value is specified for positive events. The loss specified does not indicate the true loss of the event.
- The true loss has to be measured by performing bidirectional fiber measurements and bidirectional analysis.

Description of Event Types

Launch Level

Launch Level →

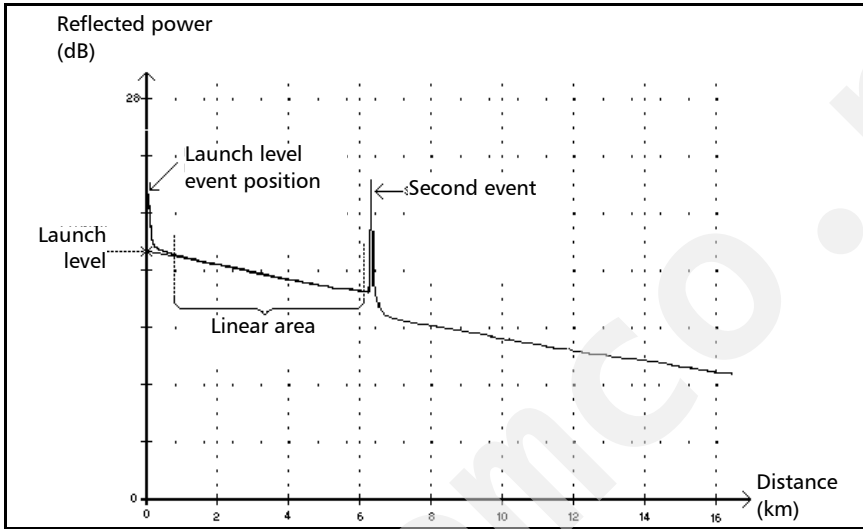

This event indicates the level of the signal launched into the fiber.

- The figure above shows how the launch level is measured.

A straight line is plotted using least-square approximation to fit all trace points in the linear area between the first and second detected events.

The straight line is projected toward the Y-axis (dB) until it crosses the axis.

The crossing point indicates the launch level.

- <<<< in the events table indicates that the launch level is too low.

Fiber Section

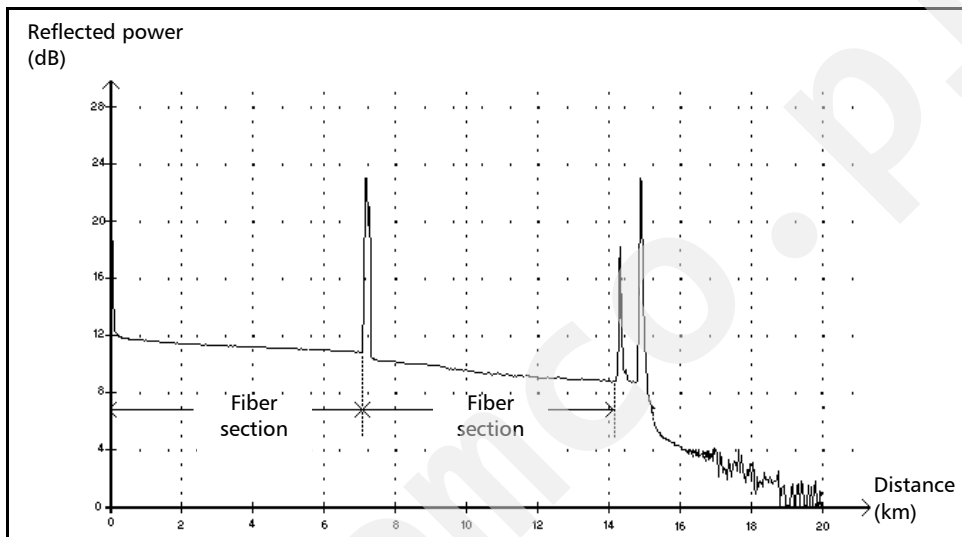

This symbol denotes a fiber section with no event.

- The sum of all fiber sections contained in an entire fiber trace equals the total fiber length. Detected events are distinct—even if they cover more than one point on the trace.
- A loss value is specified for fiber section events. No reflectance is specified for this type of event.
- Each fiber section has its own length, attenuation and loss value.

Description of Event Types

Reflective Event (Possible Echo)

Reflective Event (Possible Echo)

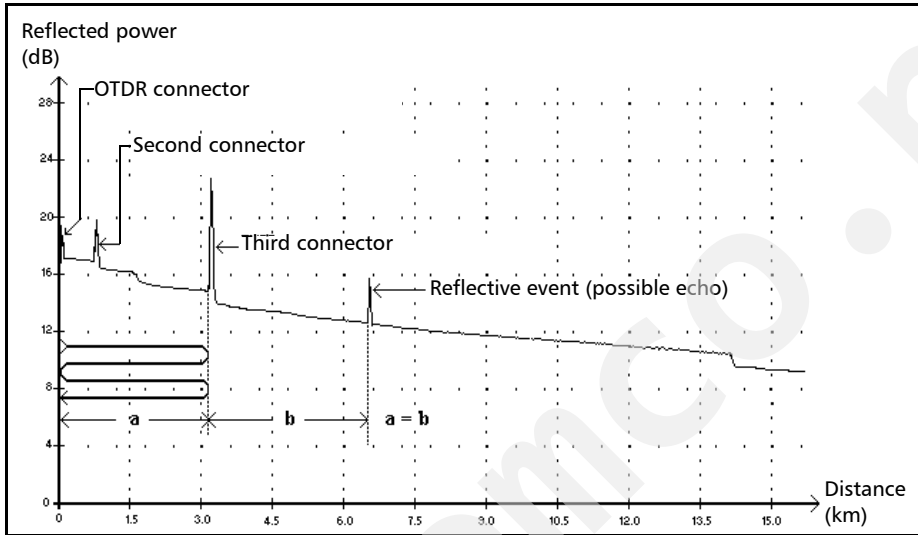

This symbol indicates a reflective event that can be a real reflection or an echo produced by another stronger reflection located closer to the source.

- In the example above, the launched pulse hits the third connector, is reflected back to the OTDR and reflected again into the fiber. It then reaches the third connector a second time and is reflected once more to the OTDR.

The application would therefore detect a reflective event located at twice the distance of the third connector. Since this event is almost null (no loss), and since its distance is a multiple of the third connector distance, The application would interpret it as a possible echo.

- A reflectance value is specified for reflective events (possible echo).

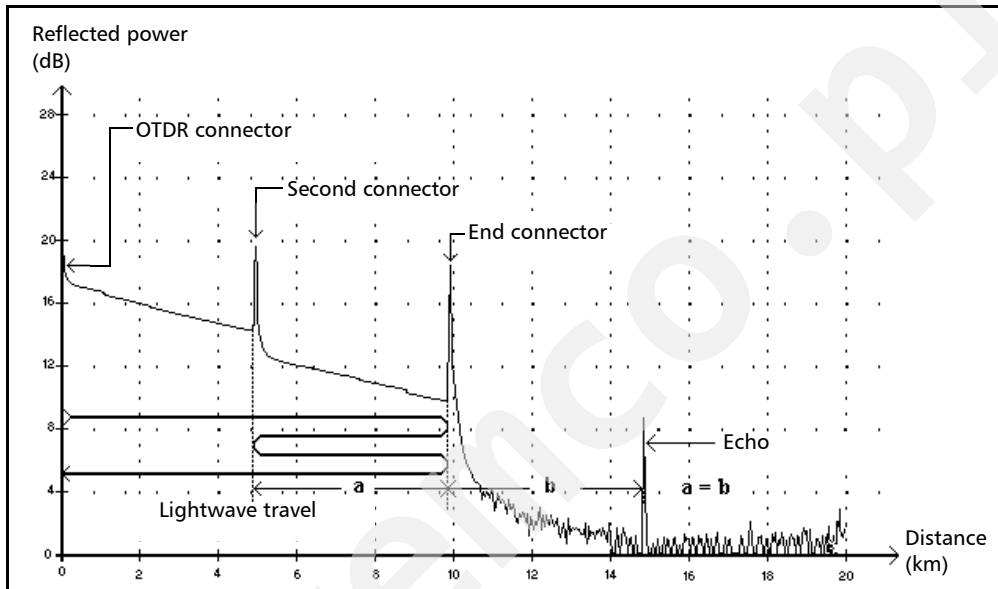
Echo Π_{nr} 

This symbol indicates that an echo has been detected after the end of the fiber.

- In the example above, the launched pulse travels up to the end connector and is reflected back toward the OTDR. Then, it reaches the second connector and is reflected again toward the end connector. It is then reflected back to the OTDR.
- The application interprets this new reflection as an echo because of its characteristics (reflectance and particular position with respect to other reflections).
- The distance between the second connector reflection and the end connector reflection is equal to the distance between the end connector reflection and the echo.
- There is no loss specified for echo events.

Description of Event Types

Merged Reflective Event

Merged Reflective Event Σ

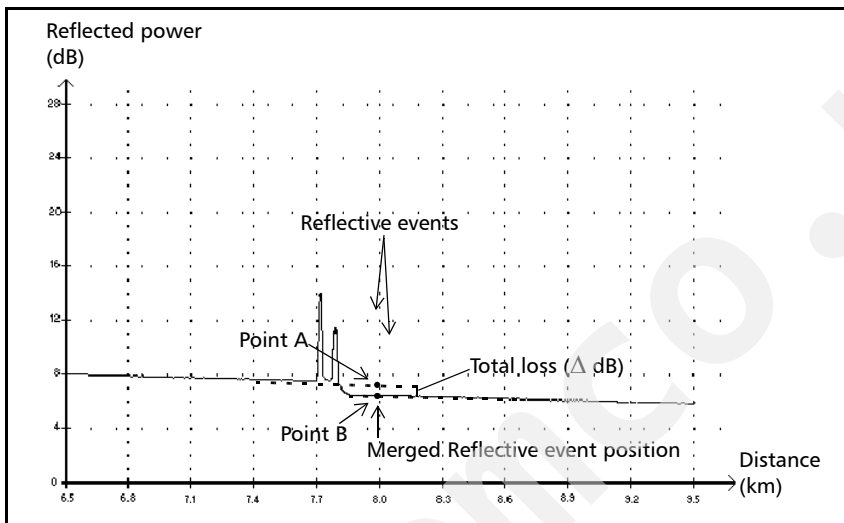

This symbol denotes a reflective event combined with one or more other reflective events. It also indicates the total loss produced by the merged reflective events following it in the events table.

- A Merged Reflective Event is composed of reflective events. Only the Merged Reflective Event is displayed in the events table, not the reflective subevents composing it.
- Reflective events may indicate the presence of connectors, mechanical splices, or poor-quality fusion splices or cracks.
- A reflectance value is specified for all merged reflective events and indicates the maximum reflectance for the merged event. A reflectance value, corresponding to the highest reflectance value among all subevents composing the Merged Reflective Event, is also displayed.

- The total loss (Δ dB) produced by the events is measured by plotting two straight lines.
 - The first line is plotted by fitting, through least-square approximation, trace points in the linear area preceding the first event.
 - The second line is plotted by fitting, through least-square approximation, trace points in the linear area following the second event. If there were more than two merged events, this line would be plotted in the linear area following the last merged event. This line is then projected toward the first merged event.
 - The total loss (Δ dB) equals the power difference between the point where the first event begins (point A) and the point on the projected straight line located just below the first event (point B).
 - No loss value can be specified for the subevents.

Description of Event Types

Reflective Event

Reflective Event ▮

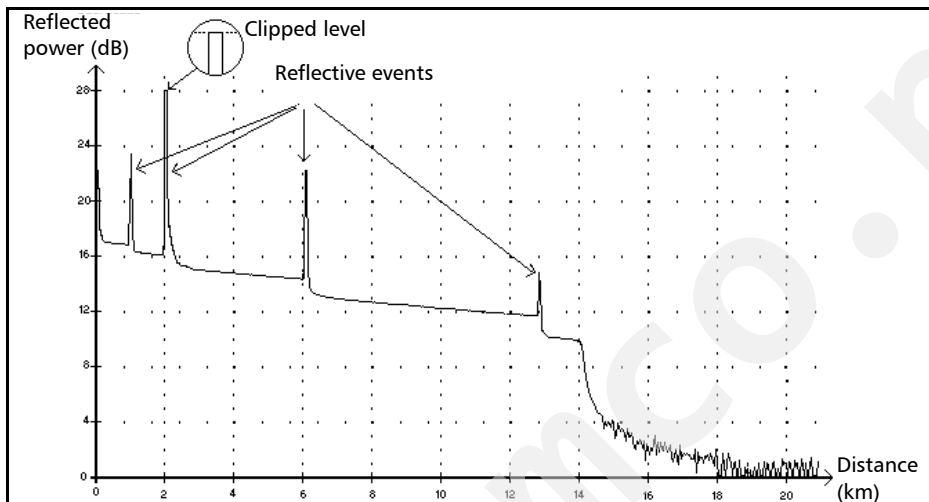

Reflective faults appear as spikes in the fiber trace. They are caused by an abrupt discontinuity in the index of refraction.

- Reflective events cause a significant portion of the energy initially launched into the fiber to be reflected back toward the source.
- Reflective events may indicate the presence of connectors, mechanical splices, or even poor-quality fusion splices or cracks.
- A loss and a reflectance value are normally specified for reflective events.
- When the reflective spike reaches the maximum level, its top may be clipped due to the saturation of the detector. As a result, the dead zone—or minimum distance for making a detection or attenuation measurement between this event and a second nearby—may be increased.
- If you set thresholds, the application indicates a reflective event in the events table, whenever a value exceeds reflectance or connector loss threshold (see *Setting Pass/Fail Thresholds* on page 30).

Index

A		C	
AC adapter/charger	5, 10	cable identification	34
acquisition		calibration	
Auto mode	38	certificate	80
Fault finder mode	41	interval	80
Manual mode	43	cancel function	13
Real time mode	46	car outlet	
starting	13	charging batteries with	78
stopping	13	power requirements	10
viewing details	54	caution	
after-sales service	89	of personal hazard	8
analysis parameters	28	of product hazard	8
applications, typical	5	certification information	vi
Auto mode, acquiring traces	38	changing batteries	79
Auto Test key	13	charge status, battery	1
automatic shut down	20	cleaning	
automatic zoom reset	23	fiber ends	22
autonaming for trace files	34	front panel	75
available memory	63	UI connectors	76
B		cold shut down	12
backlight. see brightness		comments, adding	54
backscatter	25	configuring application	15–20, ??–30
obtaining	25	connector, probe	2
reverting to default	27	connectors, cleaning	76
backscattering	7	contrast, setting	18
basic OTDR theory	6	conventions, safety	8
battery		copying files	64
charge status	1, 13, 78	creating folders	63
compartment	3	customer service	95
description	5	D	
maintenance recommendations	78	data printing	59
recharging	78	date and time setting	17
replacing or removing	11, 79	DC connector	1
brightness, setting	13, 18	deleting files	64

Index

detection thresholds	
end of fiber.....	28
reflectance.....	28
reverting to default.....	29
splice loss.....	28
disk space.....	63
disk, restoring system.....	86
display.....	1
brightness and contrast.....	18
status bar.....	13
distance	
equation.....	6
units, selecting.....	15
E	
electrical safety.....	10
end-of-fiber event.....	97
energy, saving.....	20
equation of distance.....	6
event sections, displaying/hiding.....	23
event types	
description.....	97
continuous fiber.....	98
echo.....	105
end of analysis.....	99
end-of-fiber.....	97
fiber section.....	103
launch level.....	102
merged reflective event.....	106
non-reflective event.....	100
positive event.....	101
reflective event.....	108
reflective event (possible echo).....	104
span end.....	97
span start.....	97
Events pane.....	52
exit function.....	13

F	
factory-default settings	
analysis parameters.....	29
IOR, backscatter, helix factor.....	27
pass/fail thresholds.....	31
fail value.....	30
Fault finder mode, acquiring traces.....	41
fiber	
identification.....	34
sections, displaying/hiding.....	23
fiber ends, cleaning.....	22
fiber inspection probe. <i>see</i> probe	
fiber span, automatic zoom.....	38
files	
reference trace, selecting.....	23
trace, saving.....	34
firmware version number.....	91
first connector check.....	25, 27
folders, creating.....	63
Fresnel reflections.....	7
front panel, cleaning.....	75

G	
graph grid.....	23
grid, graph.....	23
group index.....	25

H	
hazard, laser radiation.....	9–10
helix factor	
definition.....	25
reverting to default.....	27
help. <i>see</i> online help	
high loss, identifying.....	27
high reflectance, identifying.....	27

I		M	
identification		macrobend	32
fibers and cables	34	main menu	13
firmware and software versions	91	main trace	60
identification label	90	maintenance	
index of refraction. <i>see</i> IOR		battery	78
infrared port	2	front panel	75
injection level verification	27	general information	75
inspection probe. <i>see</i> probe		UI connectors	76
interface language	16	maintenance mode	86
internal memory. <i>see</i> memory		Manual mode, acquiring traces	43
IOR		markers and zoom, displaying	23
obtaining	25	memory	
reverting to default	27	available	63
K		parameters saved in	11
keypad	1, 13	menus	13
L		mode	
label, identification	90	Auto, acquisition	38
labels		Fault Finder, acquisition	41
quick reference	3	maintenance	86
safety	3	Manual, acquisition	43
language, selecting	16	Real time, acquisition	46
laser safety information	9–10	suspend	20
laser source. <i>see</i> source		monitoring traces	46
launch fiber length	28	mounting UI connector adapter	21
LCD settings	11	O	
LED, battery charge status	1	on and off, turning unit	11
light source. <i>see</i> source		online help	
Lithium-Ion battery. <i>see</i> battery	5	key for	13
loading traces	60	obtaining	88
loss thresholds	30	opening trace files	60
		ORL thresholds	30

Index

OTDR
 acquisition parameters 25
 basic theory 6
 general parameters 23
 thresholds 30

P

panes
 Events 52
 General 18
 Regional Settings 15
 Summary 23, 51
 Trace 53
 Trace Info. 54
parameters saved 11
parameters, acquisition 25
 backscatter 25
 helix factor 25
 IOR 25
parameters, analysis
 fiber span start 28
 launch fiber length 28
parameters, general 23
 fiber sections, displaying/hiding 23
 graph grid 23
 reference trace, enabling/disabling 23
 setting the 24
 Summary pane, automatic display of 23
 zoom and markers 23
parameters, macrobend 33
pass/fail thresholds
 defining 30
 reverting to default 31
PDF. see online help
photodetector 6

port
 infrared 2
 power meter 2
 printer 2
 singlemode OTDR 2
 USB 2
 VFL 2
power meter
 optional 3
 port 2
power on/off 11
power sources
 description 5
 status 13
 see also AC adapter/charger
 see also battery
printer
 port 2
 selecting 19
printing stored data 59
probe
 connector 2
 optional 3
product
 features 1
 identification label 90

Q

quick reference labels 3

R

radiation hazard, laser 9–10
Rayleigh backscatter 25
Rayleigh scattering 7
Real time mode, acquiring traces 46

-
- recalibration 80
 - rechargeable battery. *see* battery 5
 - red background, value on 30
 - reference trace 60
 - reference trace, enabling/disabling 23
 - reflectance, inaccurate measurements 26
 - reflections 7
 - regional settings 11
 - date and time 17
 - distance units 15
 - language 16
 - replacing or removing batteries 11, 79
 - results, documenting 54
 - RJ-45 connector 1
- S**
- safety
 - caution 8
 - conventions 8
 - electrical 10
 - information 9–10
 - label 3
 - warning 8
 - saving trace files 61
 - scattering 7
 - screen saver 20
 - serial number 91
 - service and repairs 95
 - service centers 96
 - shoulder strap 1
 - shut down
 - automatic 20
 - cold vs. warm 12
 - unit 12
 - signal modulation 73
 - singlemode OTDR port 2
 - software upgrade 81
- source
 - activating 72
 - signal modulation 73
 - status 72
 - wavelength, setting the 72
 - span end, description 97
 - span start, description 97
 - stand 1
 - starting an acquisition 13
 - status bar 13
 - stopping an acquisition 13
 - storage requirements 75
 - stored data, printing 59
 - storing traces 61
 - strap, shoulder 1
 - Summary pane 23, 51
 - suspend mode 20
 - symbols, safety 8
 - system disk, restore 86
- T**
- technical support 89
 - temperature for storage 75
 - test
 - starting 13
 - stopping 13
 - test parameters 11
 - test tools, light source 71
 - theory, OTDR 6
 - thresholds
 - detection, for 28
 - pass/fail settings 30
 - time and date setting 17
 - trace
 - acquisition in Auto mode 38
 - acquisition in Fault finder mode 41
 - acquisition in Manual mode 43
 - acquisition in Real time mode 46
 - saving files 34

Index

trace files	
managing	64
opening	60
saving	61
Trace Info. pane	54
Trace pane.....	53
transportation requirements	75, 91
turning unit on and off	11
typical applications	5

U

UI	
baseplate	21
connector adapter	21
dust cap.....	21
UI connectors, cleaning	76
unit recalibration.....	80
unit shutting down	12
universal interface. see UI	
upgrading the software	81
USB port.....	2, 81
user guide. see online help	

V

VFL	
optional.....	3
port	2
visual fault locator. see VFL	

W

warm shut down.....	12
warranty	
exclusions	94
general	93
liability.....	93
wavelengths.....	72

Z

zoom and markers, displaying.....	23
zoom automatic reset	23

www.vemco.pl